

Enjoy peace of mind. Register your appliance today.

Stay updated on better living services,
safety notices and shop for accessories.

1. **Open the camera app on your smartphone and point at the QR code to scan**

Product Registration QR code
is located on the front of the door
or internal side wall of your fridge.

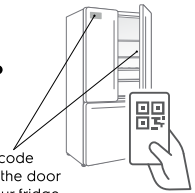

2. **Tap the notification or link to open the registration form**
3. **Complete your details and enjoy peace of mind**



Electrolux

CONTENTS

1. SAFETY INFORMATION	3
2. DESCRIPTION OF THE APPLIANCE.....	5
3. INSTALLING YOUR NEW APPLIANCE.....	6
4. TEMPERATURE CONTROL.....	9
5. USING YOUR REFRIGERATOR	15
6. CONNECTING THE WATER SUPPLY.....	18
7. AUTOMATIC ICE & WATER DISPENSER.....	20
8. GENERAL INFORMATION	22
9. FOOD STORAGE GUIDE.....	24
10. TROUBLESHOOTING	25
11. NOISES.....	29
12. WARRANTY.....	30

WE'RE THINKING OF YOU

Thank you for choosing Electrolux. We have designed this product to make your life simpler and deliver impeccable performance for many years. Please spend a few minutes reading this document to get the best from your new Electrolux appliance.

Visit our website to:



Get usage advice or service information:
www.electrolux.com





Register your product for better service:
www.electrolux.com/support/register-warranty

CUSTOMER CARE AND SERVICE

Always use original spare parts.

When contacting our Authorised Service Centre, ensure that you have the following data available: Model, PNC, Serial Number.

The information can be found on the rating plate.

-  Warning / Caution-Safety information.
-  General information and tips.
-  Environmental information.

Subject to change without notice.

1. SAFETY INFORMATION

Note: You must read these warnings carefully before installing or using the refrigerator. If you need assistance, contact your customer care center. The manufacturer will not accept liability, should these instructions or any other safety instructions incorporated in this book be ignored.



WARNING

- It is essential the electric outlet is properly earthed to ground. Consult a qualified electrician if you are unsure.
- Do not use electrical appliances inside the food storage compartments of the appliance, unless they are of the type recommended by the manufacturer.
- Unplug the refrigerator before cleaning or moving it to avoid electric shock.
- Never unplug the refrigerator by pulling the electrical cord as this may damage it. Grip the plug firmly and pull straight out.
- If the power cord is damaged, it must be replaced by the manufacturer, its service agent or similarly qualified persons in order to avoid a hazard.
- Don't use a steam cleaner. If live components come into contact with condensing steam, they may short-circuit or cause an electric shock.
- Do not store explosive substances such as aerosol cans with a flammable propellant this appliance. If pressurized aerosol containers bear the word 'flammable' and/or a small flame symbol, do not store them inside any refrigerator or freezer. If you do so you may cause an explosion.
- Do not damage the refrigerant circuit
- This appliance contains insulation formed with flammable blowing gases. Avoid safety hazards by carefully disposing of this appliance.
- If you wish to discard this refrigerator, please contact your local authorities and ask for the correct method of disposal.
- When you dispose of your old refrigerators and freezers, remove any doors. Children can suffocate if they get trapped inside.
- When positioning the appliance, ensure the supply cord is not trapped or damaged.
- Do not locate multiple portable socket-outlets or portable power supplies at the rear of the appliance.
- Children should be supervised to ensure that they do not play with the appliance.
- This appliance is not intended for use by persons (including children) with reduced physical, sensory or mental capabilities, or lack of experience and knowledge, unless they have been given supervision or instruction concerning use of the appliance by a person responsible for their safety.



WARNING

R600a refrigerant warning



This appliance contains flammable R600a refrigerant. Avoid safety hazards by carefully installing, handling, servicing and disposing of this appliance.

- Ensure that the tubing of the refrigerant circuit is not damaged during transportation and installation.
- Leaking refrigerant may cause eye injuries or ignite.
- The room for installing appliance must be at least 1m² per 8g of refrigerant. The amount of refrigerant in the appliance can be found on the rating plate inside the appliance.
- If you are unsure of the refrigerant check the rating plate inside the refrigerator compartment.
- It is hazardous for anyone other than an Authorized Service Person to service this appliance. In Queensland Australia the Authorization Service Person **MUST** hold a Gas Work Authorization for hydrocarbon refrigerants to carry out servicing or repairs which involve the removal of covers.
- Keep ventilation openings in the appliance enclosure or in the built-in structure, clear of obstruction.
- Do not use mechanical devices or other means to accelerate the defrosting process, other than those recommended by the manufacturer.



WARNING

Stable Footing

When your refrigerator is in place, you need to stabilize it. Lift the front of the refrigerator to take the weight off each stability foot and make small quarter turns to each foot until it is in firm contact with the floor. If you intend to move the refrigerator, remember to wind up each foot so that you can move it freely. Repeat the process of the foot adjustment once you have settled on the new location of the refrigerator.

Side View

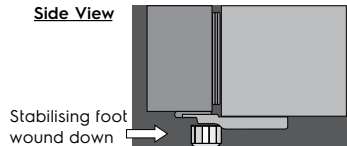

GENERAL WARNINGS

Read the following carefully to avoid damage or injury. It is important to use your refrigerator safely. Check these safety points before using your refrigerator.

- The appliance must be plugged into its own dedicated electrical outlet.
- The plug must be accessible when the refrigerator is in position.
- It is essential the power point is properly pored to ground. Consult a qualified electrician if you are unsure.
- Don't use extension cords or adapter plugs with this refrigerator.
- If the supply cord is damaged, it must be replaced by the manufacturer, its service agent or similarly qualified persons in order to avoid a hazard.
- Unplug the appliance before cleaning and before changing the light bulb(when fitted) to avoid electric shock.
- Never unplug the refrigerator by pulling the electrical cord as this may damage it. Grip the plug firmly and pull straight out.
- Choose a location for your refrigerator that isn't too cold. The ambient room temperature should be above 10°C.
- Stand your refrigerator in a dry place avoid areas of high moisture or humidity.
- Don't put the refrigerator in frosty or unprotected areas like a garage or on the verandah.
- Don't plug your refrigerator into a timer fitted to the powerpoint.
- Do not put the refrigerator in direct sunlight, near stoves, fires or heaters.
- Do not put the refrigerator on an uneven surface.
- Do not store flammable materials on or under the appliance, e.g. aerosols.
- Never store fizzy drinks in the freezer compartment.
- Never try to repair the refrigerator yourself, only use a qualified or authorized service person for repairs.
- Never use electric heaters or dryers to defrost the freezer because you can receive an electric shock.
- When transporting and installing the refrigerator, care should be taken to ensure that no parts of the refrigerating circuit are damaged.
- If the appliance is equipped with an Ice maker or a water dispenser, fill them with potable water only.

- If the appliance requires a water connection, connect it to potable water supply only.
- When installed correctly, your refrigerator should:
 - Have adequate space at the back and sides for air circulation.
 - Be vertically aligned to the surrounding cupboards.
 - Have doors that will self-close from a partially open position.

NOTE: You must read these warnings carefully before installing or using the refrigerator. If you need assistance, contact your Customer Care Department. The manufacturer will not accept liability, should these instructions or any other safety instructions incorporated in this book be ignored.



Environmental information.

This appliance is intended to be used in household and similar applications such as,

- The kitchen areas in shops, office and other working environments;
- Farm house and by clients in hotels, motels and other residential type environments;
- Bed and breakfast type environments;
- Catering and similar non-retail applications;

2. DESCRIPTION OF THE APPLIANCE

QUATTRO FRENCH DOOR REFRIGERATOR FEATURES

EHE6191

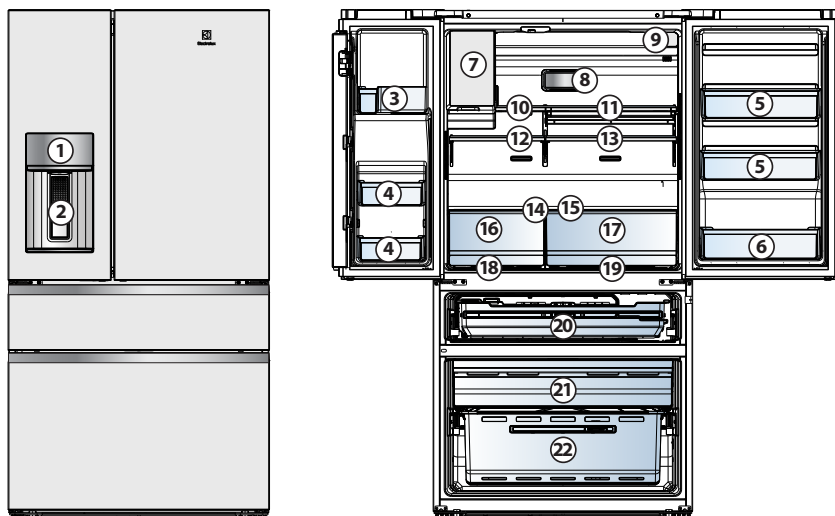

The details of the refrigerator feature:

- | | | | |
|-----------|------------------------------------|-----------|-----------------------|
| 1 | Refrigerator/Freezer control panel | 12 | Left glass shelf |
| 2 | Water and Ice Dispenser Trigger | 13 | Right glass shelf |
| 3 | Upper fixed door bin | 14 | Crisper shelf cover |
| 4 | Left fixed door bin | 15 | Auto Humidity control |
| 5 | Full width bin | 16 | Left crisper drawer |
| 6 | Bottle storage bin | 17 | Right crisper drawer |
| 7 | Ice Maker | 18 | Left Snack Zone |
| 8 | Deodorizer | 19 | Right Snack Zone |
| 9 | Water filter | 20 | Convertible drawer |
| 10 | Flip up glass shelf | 21 | Upper freezer drawer |
| 11 | Slide/fold glass shelf | 22 | Lower freezer basket |

Features may vary depending on model. Not all models will have features listed.

3. INSTALLING YOUR NEW APPLIANCE

UNPACKING



Environment

Most of the packing materials are recyclable. Please dispose of those materials through your local recycling depot or by placing them in appropriate collection containers.

Important – check for any damages or marks. If you find the refrigerator is damaged or marked, you must report it within 7 days should you wish to claim for damage/ marks under the manufacturers warranty. This does not affect your statutory rights.

Clean your refrigerator thoroughly following the instructions in the “Cleaning” section and wipe off any dust that has accumulated during shipping.

LOCATING THE REFRIGERATOR



CAUTION

Automatic aerosol systems (such as insect control) should not be located adjacent to the product as the spray may cause long term damage to the external plastics of the appliance.

Do not put the refrigerator in a location that is too cold or is unprotected, for example in a garage or on a veranda. The ambient temperature should be above 10°C.

Put the refrigerator in a dry place avoiding areas of high moisture or humidity.

Ensure the refrigerator is located on an even surface.

Adequate ventilation around your refrigerator

The diagram below shows the recommended airspace to allow for ventilation of your refrigerator.

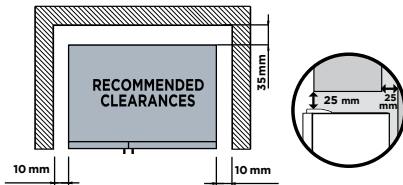

When positioned in a corner area, spacing of right side at least 260 mm and left side at least 355 mm on the hinge side will allow the doors to open enough to enable the removal of bins and shelves.

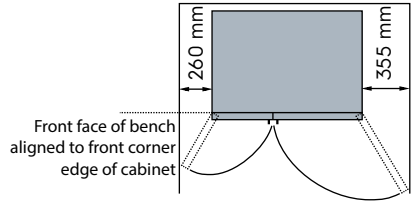

Note: Doors are designed to sit proud of cabinetry (not flush). The clearances shown above are the recommended minimum clearances.

INSTALLING YOUR REFRIGERATOR

Allow the following clearances for ease of installation, proper air circulation, and plumbing and electrical connections:

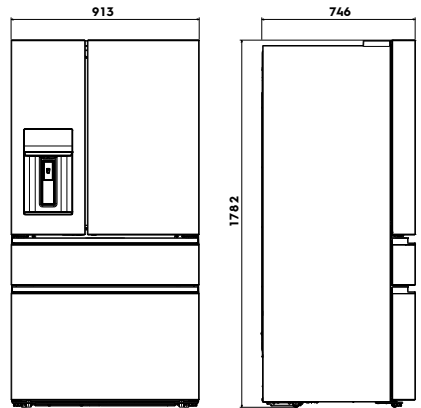

Note: If your refrigerator is placed with the door hinge side against a wall, you may have to allow additional space so the door can be opened wider.

1. Roll the refrigerator into place. The rollers are designed for forward or backward movement only. They are not castors. Moving the refrigerator sideways may damage your floor and the rollers. Before moving your refrigerator ensure height adjusting nut and the stability foot are fully wound up off the floor.

2. Wind the large height adjusting nut under door hinge down until the refrigerator is tilted back by 10mm (see diagram).

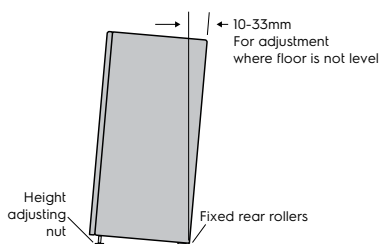

3. Wind the large height adjusting nut on the handle side down until the refrigerator is level and stable. If you have difficulty winding the nut or height adjusting foot down, have someone tilt the refrigerator back so you have better access.

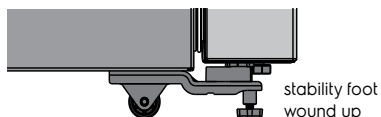

4. Check the alignment of the refrigerator to the surrounding cupboards to see if it is level. You can adjust the level as detailed in step 2 and 3.

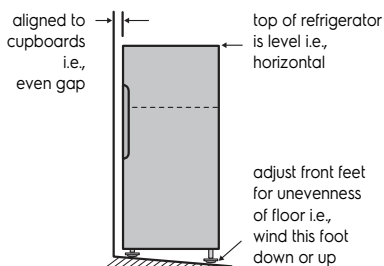

5. If you find your refrigerator rocks from corner to corner, it means your floor is uneven. Find a piece of plastic or hardboard etc. and pack it firmly under the roller.
6. You may now need to fine-tune the installation by repeating steps 3, 4 and 5.
7. When you have the appliance in its final position, it needs to be stabilised. Wind the stability foot under the door hinge down to the floor until it just makes contact with the floor. Lift the front of the appliance to take the weight off the stability foot, then turn it half a turn further to ensure firm contact with the floor. Wind the large height adjusting nut back up to ensure all the weight is now on

the front stability foot. Wind the large height adjusting nut back up to ensure all the weight is now on the front stability foot.

Front view

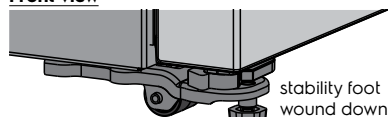

8. Repeat step 7 for the stability foot on the handle side. Whenever you need to move the appliance, be sure to wind the feet back up so that the appliance can roll freely and be sure to reset it when reinstalling.
9. Plug your refrigerator straight into its own power point and never use a double adapter. If you need to roll the refrigerator to get to the plug, remember to raise the stability foot first.
10. Before you put any food in your refrigerator, it's recommended you leave it on for 2 or 3 hours to check it is running properly.

DOOR OPENING

Your refrigerator should be positioned to allow easy access to a counter when removing food. For best use of refrigerator drawers and freezer baskets, the refrigerator should be in a position where both door can be fully opened.

Cabinet Levelling & Refrigerator Door Alignment (if necessary)

All four corners of the cabinet must rest firmly on the floor

- The front should be slightly elevated to ensure that doors close and seal properly.
- Doors should align with each other and be level.

Most of these conditions can be met by raising or lowering the adjustable front rollers.

To level the cabinet using the front rollers:

1. Slightly open freezer drawer if the toe grille is installed. Lift the toe grille and gently pull forward.
2. Make initial cabinet adjustments by using the front roller height adjusting screws. Use a 3/8 inch socket wrench to turn the adjustment screws (1 per side).

To raise: turn adjustment screw clockwise.

To lower: turn adjustment screw counter clockwise.

3. Ensure both doors are bind-free with their seals touching the cabinet on all four sides and that cabinet is stable.
4. After unit is leveled, lower anti-tip leg using a 3/8 inch socket wrench until it firmly contacts the floor.

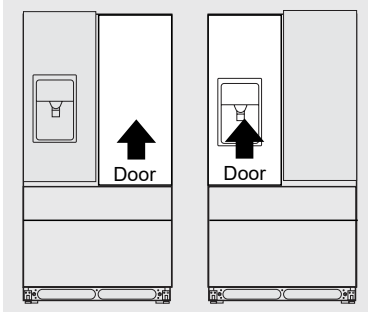

To make final door height adjustments:

1. Open freezer drawer to make lower hinge visible.
2. Insert 6mm Allen wrench into the shaft of the lower hinge.
3. Adjust the height by turning clockwise or counterclockwise. Turning wise will lower the door. Turning counterclockwise will raise the door. Default setting is to the lowest height when you receive your appliance.

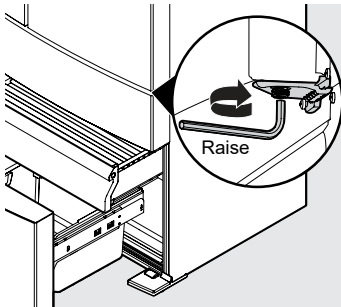

FLIPPER MULLION

Adjust Flipper Mullion for proper connection with the mullion guide by ensuring the flipper mullion is folded and perpendicular to the fresh food door. If the mullion guide is not in the correct position, it could prevent the door from closing completely.

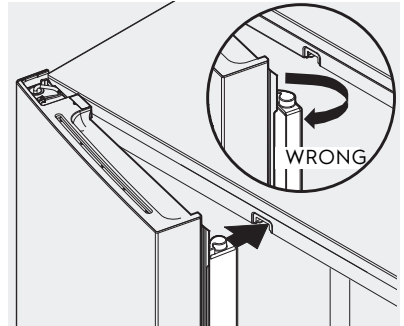

BUTTON/ ICON	DESCRIPTION	OPERATION / PRIMARY FUNCTION
3	HOLIDAY	Holiday Mode operates the product at the maximum energy efficiency when the user is away for an extended period. Conserves energy by increasing the time between automatic defrost. Only during the first 30 minutes after enabled, the user can open the doors without turning OFF the vacation function.
4	QUICK FREEZE	Prior to grocery shopping activate QUICK FREEZE to lower the temperature and freeze food faster. QUICK FREEZE stays active for up to 24 hours before automatic deactivation. You can turn it off manually by pressing QUICK FREEZE . This restores the freezer to the previous temperature setting.
5	Freezer temperature adjustment buttons	Press either the + or - to adjust the temperature. The temperatures range from -23°C to -13°C.
6	High temp	The alarm will show if the temperature of the Freezer compartment goes above 12°C for too long (45min). The alarm will be turned off if there is an interaction of the user on the UI or the door opens.
7	Ice Maker Off	This indicator is lit when the Ice Maker is off.
8	Door Open	If the door is left open for 5 minutes or more, the Door Open indicator illuminates and the audible alert is on. Press the Door Open button or close the door to turn off the alert. If the door is left open for 5 minutes, the interior light turns off.
9	*F/°C	To toggle between Fahrenheit (°F) and Celsius (°C), simultaneously press and hold + and - for 5 seconds on refrigerator side of the display.
10	Refrigerator temperature adjustment buttons	Press either the + or - to adjust the temperature. The temperatures range from +1°C to +7°C.
11	DRINK CHILL TIMER	Press DRINK CHILL TIMER to quickly chill a drink inside the freezer compartment. A time value appears on the freezer temperature display (in minutes). Set the timer using the + / - buttons. The range is from 20 to 45 minutes in 5 minute intervals. A tone sounds when you input the time. Drinks may freeze if the temperature is too low or timer setting is too long.  WARNING When using the cold drink timer, remove drinks from the freezer compartment when the alarm sounds. Carbonated drinks may explode if left in the freezer for too long.
12	RESET AIR FILTER	Filter condition status is always displayed when the door is open. Press and hold RESET AIR FILTER button for 3 seconds to reset after changing the filter.
13	RESET WATER FILTER	Press and hold RESET WATER FILTER button for 3 seconds to reset after filter change.

BUTTON/ ICON	DESCRIPTION	OPERATION / PRIMARY FUNCTION
14	LIGHT	Press to switch the dispenser light on and off.
15	CONNECT	Press and hold the “ CUBES ” and “ LIGHT ” buttons to enable/disable wireless connection. When LED is on the product is connected. When LED is flashing the product is connecting. When the LED is off, Wi-Fi connectivity is disabled. Press and hold for 10 seconds to reset wireless connection
16	CUBE	Press the CUBES key to select cubed ice. The indicator is lit above the active feature.
17	CRUSH	Press the CRUSHED key to select crushed ice. The indicator is lit above the active feature.
18	LOCK	The Lock prevents the display from unintended use. Press and hold “ WATER and CRUSHED ” button for 3 seconds to enable/disable. While Lock is enabled, you cannot change settings on the display. Dispensing ice and water is disabled. When you interact with the display, the indicator flashes, and an audible warning tone sounds.
19	WATER	Press the WATER key to select water. The indicator is lit above the active feature.
20	Replace air filters	It illuminates every 6 months or when filter needs replacing. Replace the filter. Press and hold RESET AIR FILTER button for 3 seconds to deactivate the warning on the display. Refer to Filter Replacement
21	Replace water filter	It illuminates every 6 months or after dispensing 120 gallons of water. Replace the filter. Press and hold RESET WATER FILTER button for 3 seconds to deactivate the warning. Refer to Filter Replacement
	Awake Mode	To change from sleep mode (on) to awake mode (off), simultaneously press “ ICE MAKER ” + “ LIGHT ” and hold for 5 seconds. Display will show the current temperature/ice maker status. Tone will confirm
	Sleep Mode	As a default, the display will go to sleep after a short time. If any icon is pressed, the display will be awakened. After a short time, it will go back to sleep. When in sleep mode, wake up the display to confirm ice maker is On/Off. Sleep mode can be turned off to have the display on full time (awake mode). When sleep mode is Off, the display will always be illuminated. To turn sleep mode On/Off, simultaneously “ ICE MAKER ” + “ LIGHT ” and hold for 5 seconds. Tone will confirm.

Sabbath Mode

The Sabbath Mode is a feature that disables portions of the refrigerator and its controls in accordance with observance of the weekly Sabbath and religious holidays within the Orthodox Jewish community.

Sabbath Mode is turned ON and OFF by simultaneously pressing and holding both the “-” (freezer side) and “+” (refrigerator side) for 5 seconds. Other than the High Temp alarm, no audible sounds will occur until the user exits the Sabbath mode. The display shows “Sb” while in Sabbath mode.

In the Sabbath Mode, the High Temp alarm is active for health reasons. For example,

If the door is left ajar the High Temp alarm is activated. The refrigerator will function normally once the door is closed, without any violation of the Sabbath/Holidays. The High Temp alarm is permitted while the High Temp icon stays lit until the Sabbath mode is exited.

Note: While in Sabbath Mode, neither the lights, dispenser, nor the control panel will work until Sabbath Mode is deactivated.

Refrigerator stays in Sabbath Mode after power failure recovery. It must be deactivated with the buttons on the control panel.

Although you have entered the Sabbath Mode, the ice maker will complete the cycle it had already initiated. The ice cube compartment will remain cold and new ice cubes can be made with standard trays.

WI-FI CONNECTIVITY SETUP

This chapter describes how to connect the smart appliance (fridge) to the Wi-Fi network and to link it to mobile devices.

By this functionality you can receive notifications, control and monitor your fridge from your mobile devices.

To connect the appliance to enjoy the full range of features and services you need:

- Wireless network at home with internet connection enabled.
- Mobile device connected to wireless network.

Frequency: 2.412 - 2.472 GHz

Protocol: IEEE 802.11b/g/n

Wi-Fi security protocol: WPA or WPA2 must be enabled on the network

Follow these easy steps to connect your fridge.

1. Download and install the Electrolux App.



Minimum requirements: iOS 17.0/Android 11 and above. You will need to install the Electrolux app, create an Electrolux account and accept the Terms and Conditions and Electrolux's Privacy Policy in the app to use the connected features of the fridge. Internet and Wi-Fi connections are required to use the full features of the app and the fridge. Minimum requirements, apps and services

2. Create an Electrolux account You can only create one Electrolux account per product. This account can be shared across multiple devices.
3. Setting Up Your Fridge Make sure your fridge is plugged in and working properly. Tap the “+” button at the top of the home screen and follow the on-screen instructions.

*Setup may take a few minutes depending on your network speed

4. Turning on your fridge Wi-Fi Initially your fridge creates its own Wi-Fi network to assist in setting up. After setup this network disappears and your fridge will connect to your home Wi-Fi network.

Press and hold the "Cubes" and "Light" button on the fridge for 3 seconds until the Wi-Fi icon starts flashing

The fridge is now creating a temporary network for the next step

5. Your refrigerator is now ready to connect to your home Wi-Fi network.

Please follow the instructions in the Electrolux app to complete the setup.

6. Connect your fridge to your home Wi-Fi

You'll need to select your Wi-Fi network name and input your password.

*For iOS devices, you will then be prompted go to 'SETTINGS' on your phone and select your Home Wi-Fi, then return to the Electrolux app.

Connection success!

Please proceed to the next screen to register the appliance.

7. Product registration

Simply add your fridge's name and the purchase date.

Congratulations!

Now you're all set up, you can start exploring the Electrolux App

Useful Alerts on your App



Fridge Door Open

The door has been open for more than five minutes. Please close it to save energy and avoid the loss of cold air.



Drinks Chill

The drinks in your freezer are now chilled. Please remove them from the freezer to avoid freezing.



Water Filter

Ensure you always have fresh filtered water, as you get a reminder when it's time to change the filter cartridge.

Other Cool Features of your Fridge

Easy Glide Crispers

Automatic humidity control ensures your fruit and vegetables are preserved in the optimal environment. Designed with your comfort in mind, the easy glide crispers open effortlessly and provide easy access even when they're full.

SmartSplit Door Design

With optimally split doors you have more usable space in your refrigerator door and can effortlessly reach for larger items, saving you the need to open both doors every time.

Flip Up Shelves

With the ability to flip up some of the refrigerator shelving your taller Instagram worthy creations stay in one piece, ready for their big reveal



IMPORTANT

The factory default settings for the refrigerator is "3°C" and "-18°C" for the freezer. If you want to change the temperature, remember to make only small adjustments and wait 24 hours to see if it's correct

SETTING COOLING TEMPERATURES

NOTE: The recommended settings for a product installed in a kitchen is 3°C for the fresh food compartment and -18°C for the freezer.



IMPORTANT

If your product has food freezing in the fresh food compartment, increase the temperature setting 1 or 2 degrees. If you place food within 1 inch in front of the air ports, there may be the chance of freezing food.

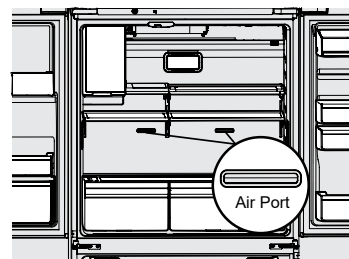

NOTE: Control features and alarms may vary by model.

Alerts and Alarms

Water Filter

When illuminated, the water filter needs to be replaced. Change the water filter every 6 months or when 120 gallons of water has been dispensed. To reset, press and hold button for 3 seconds. Tone will sound once it has been reset

Air Filter Installation

Prior to installation, the air filter pack can be located in the left crisper inside the refrigerator. Please follow instructions below on how to install the air filter.

Carbon activated air filter

8. Remove plastic wrap.
9. Install filter according to your refrigerator's use&care guide on page 20 of this manual.
10. Reset filter reminder light on your refrigerator.
11. Replace filter every 6 months.

When illuminated, air filter needs to be replaced. Change the air filter every 6 months. To reset, press and hold button for 3 seconds. A "beep" sound will confirm the reset is successful.

Door Open

If a door has been left open for 5 minutes or more, an alarm will sound and the door open indicator will illuminate on the display. The alarm can be turned off by closing the door or pressing any key. Control panel will return to normal operations after the door is closed.

Error tone

An alarm will sound if the user tries to make a selection that is not available.

How to change the °F/°C Mode

Press and hold for 5 seconds Temperature refrigerator "+" and "-" Buttons The display will change to "°F/°C" then revert to either °F/°C mode



5. USING YOUR REFRIGERATOR

Refrigerators work by transferring heat from the food inside to the outside air. This operation makes the back and sides of the refrigerator feel warm or even hot particularly at start-up and on warm days - this is normal.

Avoid placing food against the air vents in the refrigerator as it affects efficient circulation. If the door is opened frequently, a light frosting will occasionally occur on the freezer's interior. This is normal and will clear after a few days. If the freezer door is accidentally kept open, a heavy frost will coat the inside walls and should be removed.

Your new refrigerator uses a high-speed compressor, along with other energy-efficient components, which may make unusual sounds and be more noticeable at night and quieter times. These sounds simply indicate your refrigerator is working how it should. They include:

- Compressor running noises;
- Air movement noise from the small fan motor;
- A gurgling sound, similar to water boiling;
- A popping noise, heard during automatic defrosting; and
- A clicking noise, prior to compressor start-up. Further details can be found in the Troubleshooting Guide



CAUTION

LED lighting

Your appliance is fitted with long life LED lighting. In the unlikely event the LED lights should fail, then the LED lights should be serviced by the service agent, to avoid a safety hazard. Refer to the warranty page for contact details.

SHELVES



CAUTION

To avoid personal injury or property damage, handle tempered glass shelves carefully. Shelves may break suddenly if nicked, scratched, or exposed to sudden temperature change. Allow the glass shelves to stabilize to room temperature before cleaning. Do not wash in dishwasher.

You can easily adjust shelf positions in the fresh food compartments to suit your needs. The shelves have mounting brackets that attach to slotted supports at the rear of each compartment.

To change a shelf position:

1. Remove all food from shelf.
2. Lift the front edge up and pull the shelf out.
3. Replace by inserting the mounting bracket hooks into the desired support slots.
4. Lower the shelf and lock into position.

To adjust the flip shelf:

1. Remove food from shelf.
2. Lift the right side edge of shelf upwards and push to the left towards ice maker.

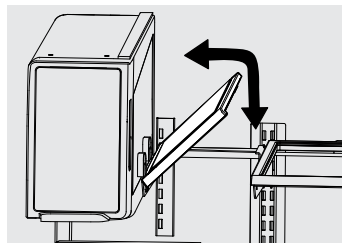

Flip Shelf

To adjust the slide-under/flip shelf:

1. Pull front half shelf forward until its back drops down, then gently push front half shelf back and under back half shelf.

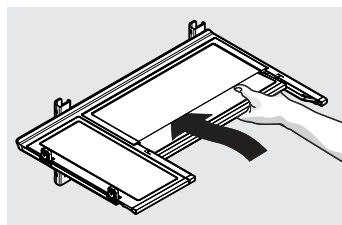

Slide-Under/Flip Shelf

2. With front half fully below back half, lift front of shelf to flip it upwards toward the back of the cabinet.

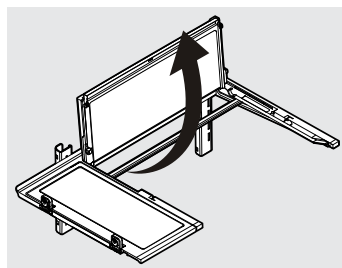

Slide-Under/Flip Shelf

DRAWERS

Your refrigerator includes a variety of storage drawers.

Crisper cover with automatic humidity control (AHC)

Crisper drawers are designed for storing fruits, vegetables, and other fresh produce. Crispers have an auto humidity control (with replaceable membrane) on the back of each crisper under the humidity control cover.

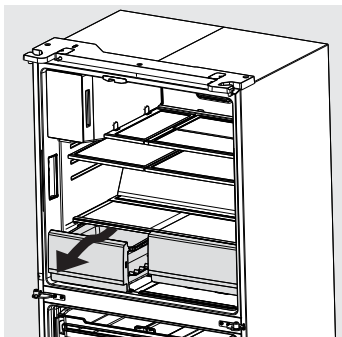

To remove the auto humidity control membrane:

1. Remove the cover crisper from the cabinet.
2. Push all snap lock AHC at the back side of cover.

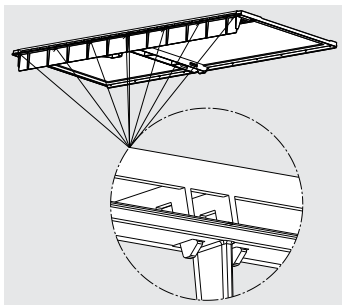

3. Pull AHC up the cover.
4. Pull towards the back of cover and remove.

5. Replace humidity membrane.

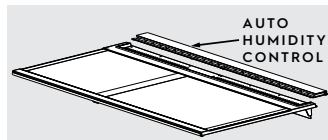

6. Replace cover by reversing the steps above.
7. Repeat for both crispers.

To remove the Crisper drawer for cleaning:

1. Pull the drawer out until it stops.
2. Lift the front slightly and remove the drawer.

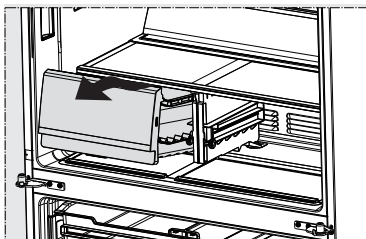

Removing drawer for cleaning

Recessed SnackZone

This drawer is ideal for storage of deli meats and cheese.

Slide back the cover to allow access to the drawers.

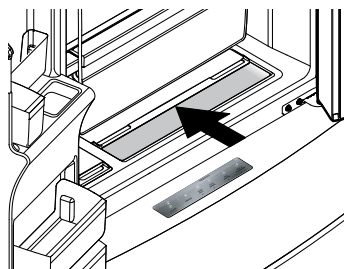

Opening the SnackZone

DOORS

Storage bins

The doors to your fresh food compartment use a system of modular storage bins. All of these bins are removable for easy cleaning. Bins can be adjusted to your needs.

Door bins are ideal for storing jars, bottles, cans, and large drink containers. They also enable quick selection of frequently used items.

To move door bin from rail to rail:

1. Lift bin up disengaging the hook.
2. Move bin to desired rail location.
3. Push bin hook into rail engaging the hook.

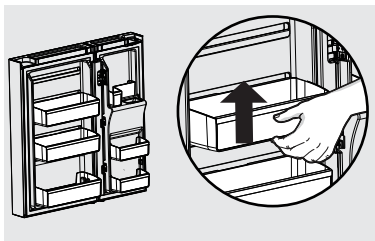

Adjustable Door Bins

FREEZER FEATURES

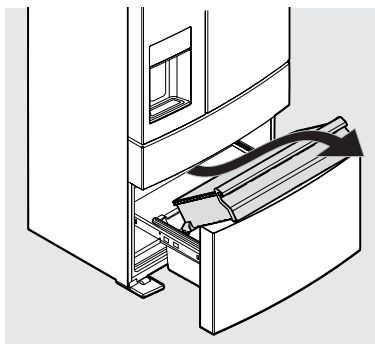

Freezer Basket

To remove upper freezer basket:

1. Open freezer compartment completely.
2. Lift up and out to remove upper freezer basket.

Reverse the steps to reinstall basket.

i IMPORTANT

There are wheels on the bottom of the drawer. Make sure all wheels are aligned on their respective tracks for proper function. If drawer is not aligned properly, it will cause problems with the door operation.

Note: If basket is not resting on stabilizer bar retainer clips, the drawer will not close properly.

To remove lower freezer basket:

1. Open freezer compartment completely.
2. Lift the basket up and remove.

Reverse the steps to reinstall drawer.

Dividers

Grab hand hold on lower divider and pull up slightly to slide to next position. (The divider cannot be removed.)

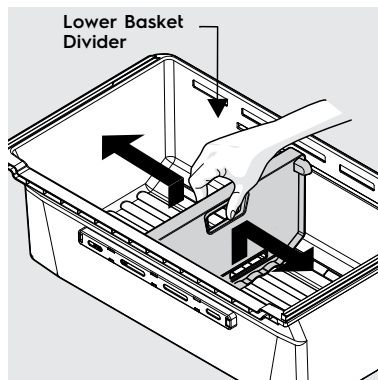

Lower Basket Divider

6. CONNECTING THE WATER SUPPLY



WARNING

To avoid electric shock, which can cause death or severe personal injury, disconnect the refrigerator from electrical power before connecting a water supply line to the refrigerator.



WARNING

To Avoid Property Damage:

- DO NOT install water supply tubing in areas where temperatures fall below freezing.
- Chemicals from a malfunctioning water softener can damage the ice maker. If your home has a water softening system, ensure the softener is maintained and working properly.



IMPORTANT

Ensure that your water supply line connections comply with all local plumbing codes.

The appliance complies with the relevant back-flow prevention requirements specified in AS/NZS 2845.1

Before Installing the Water Supply Line, You Will Need:

- Basic Tools: adjustable wrench, flat-blade screwdriver, and Phillips™ screwdriver
- The water dispenser and automatic ice maker require a drinkable water supply with a pressure range of between 206kPa and 689kPa (30PSI and 100PSI). If the water supply is above 100psi a pressure limiting valve should be installed.
- A water supply to suit a ½" tap fitting is required adjacent to the refrigerator. It is recommended that a licensed plumber install a new water supply outlet nearer to the appliance should the tubing supplied not be long enough. It is not recommended that the tubing be extended as this could adversely affect the flow of water to the ice maker or water dispenser. If there is a risk of flow rate higher than the maximum flow rate 2.46 L/min, a flow controller should be installed.



WARNING

Connect to potable water supply only. If using tank or bore water it is recommended to also use an external filter (not supplied).

The new hose-sets supplied with the appliances must be used and old hose-sets should not be reused.

Never connect the appliance to a hot water supply. Do not use with water that is micro-biologically unsafe or with water of unknown quality without adequate disinfection.

Contents of installation kit

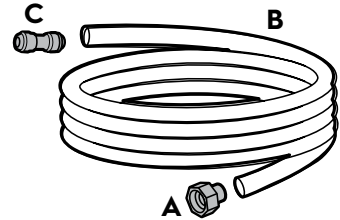

Figure 1

A - Adapter ½ to ¼ inch to connect the water supply outlet to the water supply line.

B - Water supply line ¼ inch with 3 meters in length.

C - ¼ inch connector to connect the water supply line to the refrigerator tube.

1. Disconnect the refrigerator from the power source.
2. Attach the adapter (item A above) to the water line, connect the water supply line (item B) to the adapter (item A) while holding the other end of the water supply line in a bucket or sink Turn on the water supply to eliminate air and clean the water supply line. Turn off the water supply.
3. Remove the plastic protector from the refrigerator tube and connect the water supply line (item B) to the refrigerator tube using the connector (item C) as shown in fig. Make sure the tubes are inserted completely into the connections. Lock the tubes in the clamp to keep the correct position

4. Wrap excess water supply line behind refrigerator so that it does not vibrate with refrigerator operation. Do not twist the pipe.
5. Turn on the water supply, check that there are no leaks in the connections.
6. Reconnect the refrigerator to the power source.
7. The Ice Maker is factory-switched, within 24 hours your refrigerator will have produced ice, discard the first production.

Note: Expect the first ice harvest within first 24 hours of unit operation. To prevent any issues concerning ice production, please ensure that all water lines are primed. See "Priming the water supply system" in the "AUTOMATIC ICE & WATER DISPENSER" section.

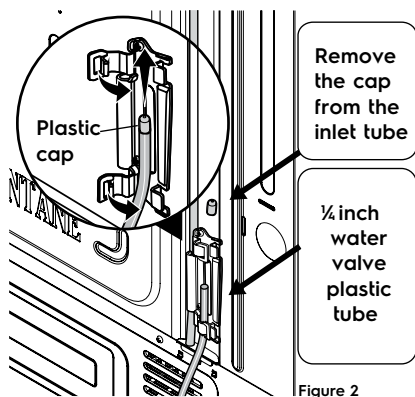

Figure 2

i IMPORTANT

Your refrigerator's water supply system includes several tubing lines, a water filter, and a water valve. To ensure that your water dispenser works properly, this system must be completely filled with water when your refrigerator is first connected to the household water supply line.

Water Filter

The water filter should not be used on water that is micro biologically unsafe or with water of unknown quality. The service life of the filter may be reduced in water supplies that contain an excess of particles or other impurities. Reduced flow rate is an indication that a new filter is required. Failure to replace the filter when required can affect the function of the ice maker. Service calls caused by a failure to replace the filter are not covered by warranty. Replacement water filters are available from Electrolux Home Products Spare Parts Centres and can be posted to you for your convenience (refer to spare parts contact numbers on the warranty page).

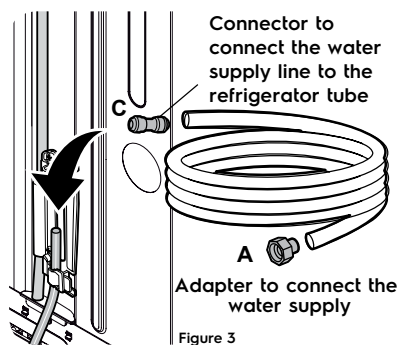

Figure 3

7. AUTOMATIC ICE & WATER DISPENSER

USING THE ICE MAKER AFTER INSTALLATION

Before making ice for the first time, be sure to prime the water supply system. Air in new plumbing lines can result in two or three empty ice maker cycles. Furthermore, if the system is not flushed, the first ice cubes may be discolored or have an odd flavor.

PRIMING THE WATER SUPPLY SYSTEM



CAUTION

For proper dispenser operation, recommended water supply pressure should fall between 30 psi and 100 psi. Excessive pressure may cause the system to malfunction.

1. Begin filling the system by pressing and holding a drinking glass against the dispenser.
2. Keep the glass in this position until water comes out of the dispenser. It may take about 1½ minutes.
3. Continue dispensing water for about four minutes to flush the system and plumbing connections of any impurities (stopping to empty the glass as necessary).

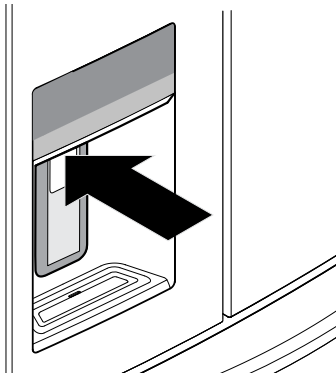

Dispenser

Note: The water dispenser has a built-in device that shuts off the water flow after two minutes of continuous use. To reset this shut-off device, simply release the dispenser paddle.

Only the first 26 ounces (750 ml) of dispensed water is chilled.



WARNING

Flushing system about 2 minutes after period of non-use exceeding 30 days

Ice maker operation & care

After the refrigerator is installed properly and has cooled for several hours, the ice maker can produce ice within 24 hours. The ice maker will fill the ice bin from the rear. You must dispense some ice to force the ice completely in the bin. This will allow the bin to fill completely.

Ice Maker and Storage Bin Capacity

This ice maker should produce 1.2 to 1.5 kg of ice per 24 hours. The ice bin will hold about 1.8 kg of ice.

Turning the ice maker on and off



IMPORTANT

Your ice maker is turned on at the factory so it can work as soon as you install your refrigerator. If you cannot connect a water supply, set the ice maker's On/Off feature to Off; otherwise, the ice maker's fill valve may make a loud chattering noise when it attempts to operate without water.

Ice production is controlled by the ice maker's On/Off feature on the control panel. Pressing the On/Off feature turns the ice maker on & off.

Note: The ice maker also has a built-in plastic signal arm that automatically stops ice production when the ice bin is full. This signal arm should not be used to manually stop the ice maker.



IMPORTANT

Turning off the ice maker simply disables ice making. You will still be able to dispense existing ice, and you will still be able to dispense water.

On occasion, unusually small ice cubes may be noticed in the bucket or in dispensed ice. This could occur in normal operation of the ice maker. If you start seeing these more frequently, it may be an indication of low water pressure, or that the water filter needs to be replaced. As the water filter nears the end of its useful life and becomes clogged with particles, less water is delivered to the ice maker during each cycle. Remember, if it has been six months or longer since you last changed your water filter, replace the water filter with a new one. Poor quality household water may require the filter to be changed more frequently.

Ice maker/dispenser tips

- If your refrigerator is not connected to a water supply or the water supply is turned off, turn off the ice maker as described in the previous section.
 - The following sounds are normal when the ice maker is operating: Motor running
 - Ice dropping into ice bin
 - Water valve opening or closing
 - Running water
- If you need a large quantity of ice at one time, it is best to get cubes directly from the ice bin.
- Ice cubes stored too long may develop an odd flavor. Empty the ice bin as explained below.
- When dispensing cubed ice, it is normal to have a small quantity of little pieces along with the whole cubes.
- To avoid splashing, dispense ice into your container before adding liquids.
- It is normal for ice to fill to the top of the ice bin.



CAUTION

If the water supply to your refrigerator is softened, be sure the softener is properly maintained. Chemicals from a water softener can damage the ice maker.

Cleaning the ice maker

Clean the ice maker and ice bin at regular intervals, especially prior to vacation or moving.

1. Turn off the ice maker.
2. Remove the ice bin by pulling straight out.
3. Empty and carefully clean the ice bin with mild detergent. Do not use harsh or abrasive cleaners. Do not place in dishwasher. Rinse with clear water.
4. Allow the ice bin to dry completely before placing it back into the freezer.
5. Place ice bin back into position. Turn the ice maker on.

Remove and empty the ice bin if:

- An extended power failure (one hour or longer) causes ice cubes in the ice bin to melt and refreeze together after power is restored, jamming the dispenser mechanism.
- You do not use the ice dispenser frequently. Ice cubes will freeze together in the bin, jamming the dispenser mechanism.

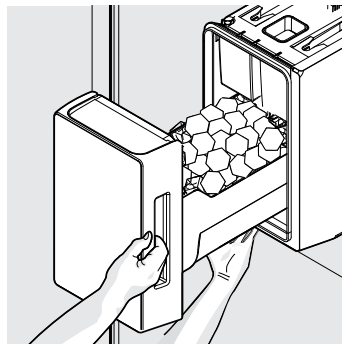

Removing Ice Bin

Remove the ice bin and shake to loosen the cubes or clean as explained above.



CAUTION

NEVER use an ice pick or similar sharp instrument to break up the ice. This could damage the ice bin and dispenser mechanism.

To loosen stuck ice, use warm water. Before replacing the ice bin, make sure it is completely dry.



IMPORTANT

When removing or replacing the ice bin, avoid rotating the auger in the ice bin. If the auger is accidentally rotated, you must realign the auger by turning it in 45 degree turns (see below) until the ice bin fits into place with the drive mechanism. If the auger is not properly aligned when replacing the ice bin, the refrigerator will not dispense ice. The fresh food door also may not close properly causing warm air to leak into the fresh food compartment.

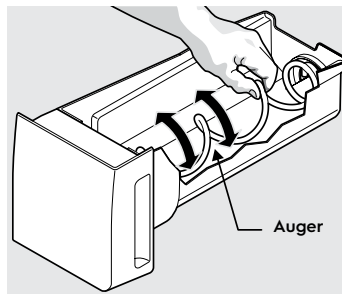

Adjusting the ice bin Auger

8. GENERAL INFORMATION

CLEANING YOUR REFRIGERATOR



WARNING

BEFORE CLEANING: Turn the refrigerator off at the power point and unplug the cord to prevent any chance of electrocuting yourself.

Doors and exterior (white and silver):

You should only clean the doors with lukewarm soapy water and a soft cloth.

Stainless Steel:

Your stainless steel refrigerator is manufactured from mark-resistant stainless steel. This stainless steel has a special advanced protective coating that eases the removal of marks such as fingerprints and water spots. To keep its appearance, clean it regularly with lukewarm soapy water and a soft cloth.



CAUTION

Never use stainless steel cleaners, abrasive pads or other cleaners that will scratch the surface. Damage to the appliance after delivery is not covered by your warranty.

Interior

Clean the inside of your refrigerator regularly with a soft cloth, unscented mild soap and lukewarm water. Thoroughly dry all surfaces and removable parts and avoid getting water on the controls. Replace removable parts, plug power cord in and switch the power on before returning the food.

Ice and water

Clean the components of the ice maker/water dispenser regularly with a soft cloth, unscented mild soap and rinsing thoroughly with lukewarm water. For further information on the care and cleaning of your ice maker, ice dispenser or water dispenser refer to the section "Ice and Water Models"

Door seals

Always keep door seals clean by washing them with a mild detergent and warm water, followed by a thorough drying. Sticky food and drink can cause seals to stick to the cabinet and tear when you open the door.



CAUTION

Never use hot water, solvents, commercial kitchen cleaners, aerosol cleaners, metal polishes, caustic or abrasive cleaners, or scourers to clean your refrigerator. Many commercially available cleaning products and detergents contain solvents that will damage your refrigerator. Use only a soft cloth with an unscented mild soap and lukewarm water.

To clean a crisper or freezer bin with telescopic extension slides, simply wipe with a damp cloth and warm soapy water. Never immerse the cover in water, as this could affect the operation of the slide.

Switching off your refrigerator

If you switch off your refrigerator for an extended period, follow these steps to reduce the chances of mould.

1. Remove all food.
2. Remove the power plug from the power point
3. Thoroughly clean and dry the Interior.
4. Ensure that all the doors are wedged open slightly for air circulation.

CHANGING THE FILTER

Air Filter (select models)

The air filter is located in the top center of the fresh food compartment

Replacing your Air Filter

To ensure optimal filtering of refrigerator odors, you should change the air filter six months (The filter status light on the Touch Panel prompts you to replace the filter after six months)

1. Remove the air filter cover by squeezing the sides of the cover together and removing from liner
2. Remove the old filter and discard it
3. Unpack the new filter and snap it into the filter cover. The open face (carbon media) of the filter should be installed facing outward in the cover.
4. Replace the air filter cover by squeezing the sides and snapping it back into place.
5. To reset, press and hold Reset Air Filter on the appliance control display for 3 seconds. Tone will sounds once it has been reset

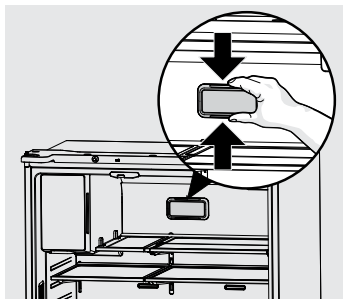

Air Filter

Water Filter

Your refrigerator is equipped with a water filtering system. The water filtering system filters all dispensed drinking water, as well as the water used to produce ice. The water filter is located at the top right side of the fresh food compartment.

In general, you should change the water filter every six months to ensure the highest possible water quality. Water filter status on the user interface prompts you to replace the filter after a standard amount of water (473 litres) has flowed through the system.

If your refrigerator has not been used for a period of time (during moving for example), change the filter before reinstalling the refrigerator

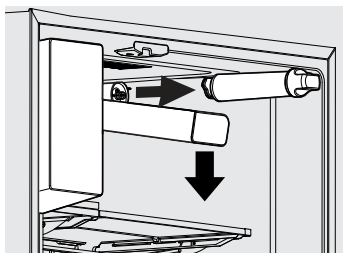

NOTE: When ordering your replacement filter, please reorder the same filter type that is currently in your refrigerator.



WARNING

Use the appliance with water filter supplied by Electrolux Home Products Pty Ltd or its authorized service agent only.

For correct operation of this appliance it is essential to observe the manufacturer's instructions.

Replacing the Water Filter

To Remove: Pull cover towards you and cover will drop down and allow access to filter.

To Reinstall: Push cover up towards liner and then push towards rear of cabinet. Filter cover will snap back into place.

It is not necessary to turn the water supply off to change the filter. Be ready to wipe up any small amounts of water released during the filter replacement

1. Ensure that the ice maker is turned off
2. Remove the filter by turning anti-clockwise 180°
3. Slide the old water filter cartridge straight out of the housing and discard it.
4. Unwrap the new filter cartridge and using the alignment guide, slide it gently into filter housing until it stops against the filter connection at the back of the housing.
5. Engage the filter by firmly rotating clockwise until the filter snaps into position (once engaged the filter cannot be rotated further).
6. Press a drinking glass against the water dispenser while checking for any leaks at the filter housing. Any spurts and sputters that occur as the system purges air out of the dispenser system are normal.
7. After filling one glass of water, continue flushing the system for about four minutes.
8. Turn on the ice maker.
9. When the filter has been replaced press and hold the 'Reset Water Filter' button for three seconds to reset the filter replace timer.
10. Replace the filter, don't take off filter cover.

9. FOOD STORAGE GUIDE

CATEGORY	PRODUCT	RECOMMENDED STORAGE TIMES FOR FRESH FOODS *			STORAGE TIPS
		REFRIGERATOR	ULTRA CHILL	FREEZER	
MEAT	Sausages and Mince	1-2 Days	3-5 Days	2-3 Months	Keep cold meat at the back of the refrigerator where it is coldest.
	Chops and Steak	3-4 Days	5-7 Days	4-6 Months	
	Cold Meats	3-5 Days	5-7 Days	4-6 Months	Plastic can cause meat to sweat if stored in refrigerator for more than a day. Roast can take up to 48 hours to defrost properly, transfer frozen roast to the refrigerator 2 days before use.
	Roasts	3-5 Days	1 week	12 Months	
POULTRY	Chicken	1-2 Days	5-7 Days	2 Months	If poultry takes on a smell or colour you are unsure about it is best to throw it out.
	Roast Chicken	3-5 Days	1 week	12 Months	
	Eggs	6 Weeks	Not Suitable	Not Suitable	Whole eggs are not suitable for freezing, slightly beaten eggs may be frozen for four months.
SEAFOOD	Whole fish and fillets	2-3 Days	5-7 Days	2 Months	Store in an airtight container or foil.
	Lobster and Crab	1-2 Days	3-5 Days	2 Months	
	Prawns	1-2 Days	3-5 Days	2 Months	Never freeze prawns in salty water as this will dehydrate the flesh.
DAIRY	Milk	Until Expiry Date	Not Suitable	Not Suitable	If dairy takes on a smell or colour and you are unsure about it, it is best to throw it out.
	Yoghurt	7- 10 Days	Not Suitable	Not Suitable	
	Hard Cheeses	2 Weeks - 2 Months	1-2 Months	2 Months (Grated)	Depending on the variety hard cheese can last from 2 weeks to 2 months.
	Soft Cheeses	1-2 Weeks	2-4 Weeks *	Not Suitable	* Texture may change depending of the type of soft cheese
	Butter	8 Weeks	3-4 Months	12 Months	
FRUIT & VEGETABLES	Every fruit and vegetable has a different shelf life. Some stay fresh for a couple of days e.g. beans, others can last for a couple of months e.g. onions.	Not Suitable	8-12 Months When freezing chop and blanch in small portions.	Keep vegetables in the crisper and away from the air vents to avoid freezing. If you wash fruit and vegetables before storing them make sure they are dry or wrap in absorbent paper before storing in the refrigerator as this can make them susceptible to rotting. Try to keep fruit and vegetables separated as fruits that give off high levels of ethylene (the ripening agent) can prematurely ripen and spoil surrounding vegetables	



IMPORTANT

*Please note, use this information as a guide only, actual storage times will vary depending on how you use your refrigerator, climatic conditions and the freshness of the food.

10. TROUBLESHOOTING

Appliance does not operate at desired temperature

In a modern frost free refrigerator / freezer, cold air is circulated around the various compartments through air vents using a high efficiency fan.

Concern	What to do
Refrigerator is too warm.	<ul style="list-style-type: none"> • Ensure food is allowed to cool before placing inside the refrigerator. • Ensure the appliance is set up as per instructions. • Ensure that contents are not obstructing the cooling vents. • Ensure the door is not held open or is being opened too frequently.
Freezer is too warm.	<ul style="list-style-type: none"> • Adjust temperature to a colder setting. • Ensure food is allowed to cool before placing inside the freezer. • Ensure the appliance is set up as per instructions. • Ensure that contents are not obstructing the cooling vents. • Ensure the door is not held open or is being opened too frequently.
Food is freezing in the refrigerator.	<ul style="list-style-type: none"> • Adjust temperature to a warmer setting. • Ensure that fruit and vegetables are stored in the crisper. Items with a high water content should not be placed near the cooling vents.
Unable to change temperature settings.	<ul style="list-style-type: none"> • Refer to function guide in Controlling Your Refrigerator. • Ensure that user interface is in "awake" mode before trying to adjust temperature settings.

Appliance noise

Your new refrigerator may make sounds that your old one didn't make. Because the sounds are new to you, you might be concerned about them. Most of the new sounds are normal. Hard surfaces, like the floor, walls and cabinets, can make the sounds seem louder than they actually are. The following describes the kinds of sounds and what may be making them.

Concern	What to do
Motor noise (compressor)	<p>Nothing. This is normal as your new refrigerator uses a variable speed compressor and fan that at start up and on warm days runs at a high speed to provide additional cooling.</p> <p>When less cooling is required the compressor and fan will run at a lower speed. Note that the compressor noise may seem louder at the start of the on cycle.</p>
A clicking noise heard just before the compressor starts.	Nothing. This is normal as your new refrigerator has an automatic switching action of the temperature control, turning the compressor on and off.
Occasional gurgling, similar to water boiling.	Nothing. As each refrigeration cycle ends, you may hear a gurgling sound due to the refrigerant flowing in your refrigerator system.
Airflow noise	Nothing, this is normal as your new refrigerator uses high efficiency fans to circulate air. Fan speed and noise may increase during periods of heavy usage or hot weather.
Rattling and other noises	<ul style="list-style-type: none"> • Ensure that the cabinet is level and stable, refer to Installation Instructions on page 5. • Check the surrounds of the appliance to ensure there is nothing touching or placed on top of the appliance. • Ensure that contents of the appliance are not placed in such a way that they are vibrating (such as bottles).

Crisper Operation

Concern	What to do
Excess moisture build up in crisper. It is normal for there to be some moisture and humidity in the crisper bin.	<ul style="list-style-type: none"> • Ensure that the crisper is not over packed.
Crisper bin cannot be removed.	<p>If crisper bin interferes with the door bins, remove door bins before removing crisper.</p> <p>Position cabinet so that the door can be fully opened.</p>
Freezing items in the crisper.	Adjust temperature to a warmer setting.

Refrigerator operation

Concern	What to do
Appliance will not run. It is normal for the freezer fan not to operate during the automatic defrost cycle, or for a short time after the appliance is switched on.	<ul style="list-style-type: none"> • Ensure that the cord is plugged into a live power outlet and outlet is switched on. • Ensure that the household circuit breaker has not tripped or that the fuse has not blown. • The appliance maybe in defrost mode, check again in half an hour.
<p>Compressor motor seems to run too long.</p> <p>At normal room temperatures, expect your motor to run about 40% to 80% of the time. Under warmer conditions, expect it to run even more often.</p> <p>The variable speed compressor and fan that at start up and on warm days runs at a high speed to provide additional cooling. When less cooling is required the compressor and fan will run at a lower speed.</p>	<ul style="list-style-type: none"> • Ensure that the doors are not held open. • Check that large amounts of warm food have not just been placed inside the appliance. • Note that the appliance will run more than normal just after you install it or when adjusting to temperature setting changes.
<p>The exterior of the appliance is warm or hot to touch.</p> <p>This is normal because the appliance transfers heat from the inside out through the outer panels and the divider between the doors.</p>	<ul style="list-style-type: none"> • Ensure the appliance has the external clearances recommended in the section "Installing your new appliance". • The exterior of the cabinet will be much warmer on warmer days it may even feel hot to touch, as the appliance is working harder.

Concern	What to do
<p>User interface will not respond</p> <p>To ensure settings are not accidentally changed the user interface will go into sleep mode when not in use.</p> <p>Press any button to wake user interface.</p>	<ul style="list-style-type: none"> • Check that the user interface is in awake mode, refer to section "CONTROL". • Check that the user interface is not locked, refer to section "CONTROL". • If the user interface is frozen turn the appliance off for five minutes for the memory to clear, then turn back on. • Check that the user interface is not in Sabbath Mode, refer to control instructions. (I&W models only).
<p>Alarms sounding</p>	<ul style="list-style-type: none"> • Check that all doors are fully closed. • Ensure that the over temperature alarm is not being activated by hot food placed in the freezer. • Check if the drinks timer has ended, refer control instructions. • Check if the Filter Replacement alert is activated, refer control instructions. (I&W models only)
<p>Frost build up</p>	<ul style="list-style-type: none"> • Check that all doors are fully closed. • Ensure that the doors are not opened too often. • Ensure that the return air vents are not blocked with packaging. • Ensure the seals are clean and not obstructed.
<p>Odours</p>	<ul style="list-style-type: none"> • The interior may need cleaning, refer to cleaning guide. • Ensure that food is stored correctly as some food, containers and wrapping can produce odours. • Check appliance for old or unusual food.
<p>Lights not working</p> <p>The LED lighting is designed to dim automatically if the door is left opened for more than 5 minutes and turn off completely if the door is open for more than 7 minutes. Closing the door will reset the timer.</p> <p>The LED lighting is also designed to turn on gradually.</p>	<ul style="list-style-type: none"> • Ensure that the cord is plugged into a live power outlet and outlet is switched on. • Ensure that the household circuit breaker has not tripped or that the fuse has not blown. • Check that the user interface is not in Sabbath Mode, refer to control instructions. • Close and re-open the door. When door has been open for 5 minutes the lights fade to 50% then after 7 minutes they will turn off.

Door operation

Concern	What to do
Freezer door pops open.	This is normal and should re-close. This happens when the refrigerator door is closed too quickly. If the freezer door stays open, it indicates that the appliance needs to be tilted backwards a little further. Refer to section "Installing your new appliance".
Self close not working.	Check if your appliance has self closing hinges as not all models do. It indicates that the appliance needs to be tilted backwards a little further. Refer to section "Installing your new appliance".
Door not sealing properly	<ul style="list-style-type: none"> • Ensure there is nothing that is preventing the door from closing such as appliance contents or items placed near the appliance. • Ensure that the crisper/freezer bin is closed completely. Refit if required as referred to in the section "STORAGE FEATURES". • Ensure the appliance is set up as per recommendations.
Door difficult to open and close	If the door is difficult to open just after you have closed it this is due to the pressure equalising, the door will open normally after a few minutes.

Automatic Ice maker system

Concern	What to do
Ice maker does not produce ice or not enough ice. The ice-maker is designed to produce a tray of ice approximately every 3 hours, depending on room temperature and water temperature.	<ul style="list-style-type: none"> • Ensure that the cord is plugged into a live power outlet and outlet is switched on. • Ensure that water is connected and turned on and there are no kinks in the water line. • Ensure that the Ice Maker is switched on at the user interface refer to "CONTROL" for details. • Check that the water filter is not blocked or out of date. • Check the water supply flow rate. • If the freezer compartment is too warm, refer to "freezer is too warm" then wait 24 hours for the freezer to reach ideal temperature. • Turn the unit off at the mains and leave for 2 minutes then turn the appliance back on (this will reset the ice-maker unit). Check for ice production after 24 hours. • Check that there is no obstruction under the ice maker and ensure the ice bin is fitted correctly.
Ice has bad odour or taste.	<ul style="list-style-type: none"> • Cover food to ensure ice does not absorb foreign odours. • Check that the water filter is not out of date. • Interior of appliance or ice bin may require cleaning, refer to "Cleaning your refrigerator". • Discard stale ice monthly and allow ice maker to produce a fresh supply

If you still require service

If you have a problem, and the problem persists after you have made the checks mentioned, contact your nearest Electrolux approved Service Centre or the dealer you bought the refrigerator from. Be ready to quote the model number, the 9-digit PNC and 8-digit serial number, which is stated on the label inside the refrigerator compartment.

11. NOISES

Appliance noise

Your new refrigerator may make sounds that your old one didn't make. Because the sounds are new to you, you might be concerned about them. Most of the new sounds are normal. Hard surfaces, like the floor, walls and cabinets, can make the sounds seem louder than they actually are. The following describes the kinds of sounds and what may be making them.

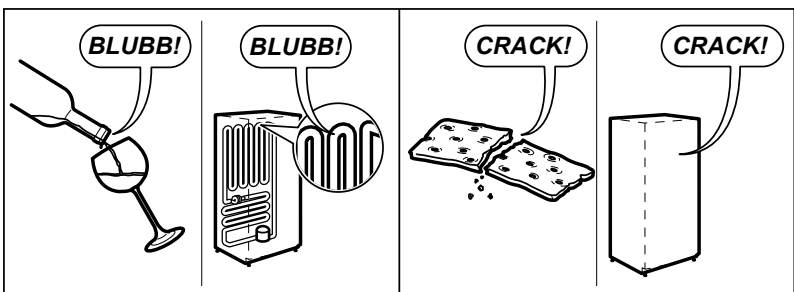
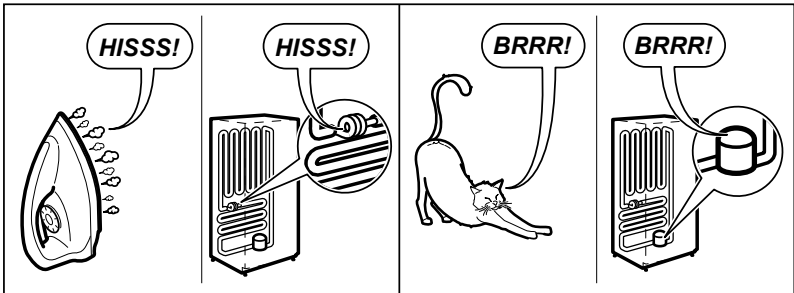
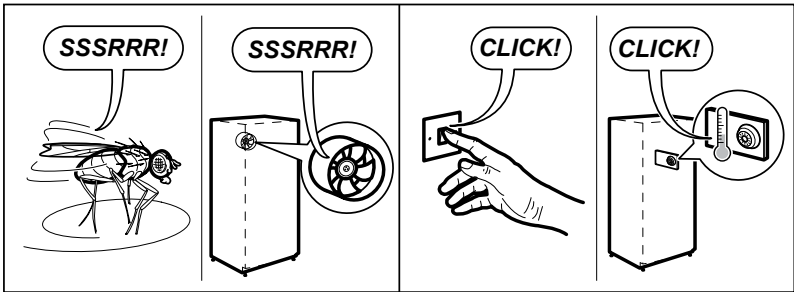
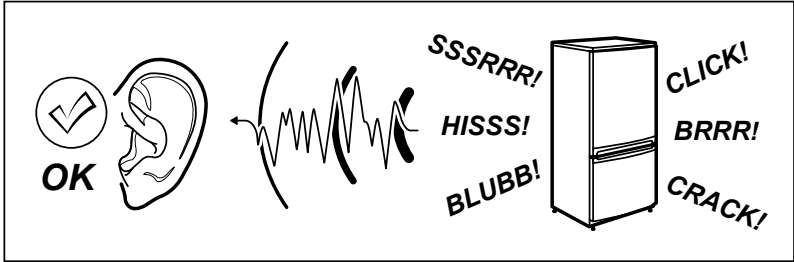

12. WARRANTY



FOR SALES IN AUSTRALIA AND NEW ZEALAND
 APPLIANCE: ELECTROLUX REFRIGERATORS AND FREEZERS

This document sets out the terms and conditions of the product warranties for Electrolux Appliances. It is an important document. Please keep it with your proof of purchase documents in a safe place for future reference should there be a manufacturing defect in your Appliance. This warranty is in addition to other rights you may have under the Australian Consumer Law.

1. In this warranty:

- (a) 'ACL' or 'Australian Consumer Law' means Schedule 2 to the Competition and Consumer Act 2010;
- (b) 'Appliance' means any Electrolux product purchased by you and accompanied by this document;
- (c) 'ASC' means Electrolux's authorised serviced centres;
- (d) 'Electrolux' is the brand controlled by Electrolux Home Products Pty Ltd of 163 O'Riordan Street, Mascot NSW 2020, ABN 51 004 762 341 in respect of Appliances purchased in Australia and Electrolux (NZ) Limited (collectively "Electrolux") of 3-5 Niall Burgess Road, Mount Wellington, in respect of Appliances purchased in New Zealand;
- (e) 'Warranty Period' means the period specified in clause 3 of this warranty;
- (f) 'you' means the purchaser of the Appliance not having purchased the Appliance for re-sale, and 'your' has a corresponding meaning.

2. Application: This warranty only applies to new Appliances, purchased and used in Australia or New Zealand and is in addition to (and does not exclude, restrict, or modify in any way) other rights and remedies under a law to which the Appliances or services relate, including any non-excludable statutory guarantees in Australia and New Zealand.

3. Warranty Period: Subject to these terms and conditions, this warranty continues for in Australia for a period of 24 months and in New Zealand for a period of 24 months, following the date of original purchase of the Appliance. Specific components are warranted against manufacturing defects in Australia and New Zealand for the periods listed below;

- Compressor – Further 3 years
- External Condenser – Further 3 years
- Evaporator – Further 3 years
- Drier – Further 3 years

4. Repair or replace warranty: During the Warranty Period, Electrolux or its ASC will, at no extra charge if your Appliance is readily accessible for service, without special equipment and subject to these terms and conditions, repair or replace any parts which it considers to be defective. Electrolux may, in its absolute discretion, choose whether the remedy offered for a valid warranty claim is repair or replacement. Electrolux or its ASC may use refurbished parts to repair your Appliance. You agree that any replaced Appliances or parts become the property of Electrolux.

5. Travel and transportation costs: Subject to clause 7, Electrolux will bear the reasonable cost of transportation, travel and delivery of the Appliance to and from Electrolux or its ASC. Travel and transportation will be arranged by Electrolux as part of any valid warranty claim.

6. Proof of purchase is required before you can make a claim under this warranty.

7. Exclusions: You may not make a claim under this warranty unless the defect claimed is due to faulty or defective parts or workmanship. This warranty does not cover:

- (a) light globes, batteries, filters or similar perishable parts;
- (b) parts and Appliances not supplied by Electrolux;
- (c) cosmetic damage which does not affect the operation of the Appliance;
- (d) damage to the Appliance caused by:
 - (i) negligence or accident;
 - (ii) misuse or abuse, including failure to properly maintain or service;
 - (iii) improper, negligent or faulty servicing or repair works done by anyone other than an Electrolux authorised repairer or ASC;
 - (iv) normal wear and tear;
 - (v) power surges, electrical storm damage or incorrect power supply;
 - (vi) incomplete or improper installation;
 - (vii) incorrect, improper or inappropriate operation;
 - (viii) insect or vermin infestation;
 - (ix) failure to comply with any additional instructions supplied with the Appliance;

In addition, Electrolux is not liable under this warranty if:

- (a) the Appliance has been, or Electrolux reasonably believes that the Appliance has been, used for purposes other than those for which the Appliance was intended, including where the Appliance has been used for any non-domestic purpose;
- (b) the Appliance is modified without authority from Electrolux in writing;
- (c) the Appliance's serial number or warranty seal has been removed or defaced.

8. How to claim under this warranty: To enquire about claiming under this warranty, please follow these steps:

- (a) carefully check the operating instructions, user manual and the terms of this warranty;
- (b) have the model and serial number of the Appliance available;
- (c) have the proof of purchase (e.g. an invoice) available;
- (d) telephone the numbers shown below.

9. Australia: For Appliances and services provided by Electrolux in Australia: Electrolux goods come with guarantees that cannot be excluded under the Australian Consumer Law. You are entitled to a replacement or refund for a major failure and for compensation for any other reasonably foreseeable loss or damage. You are also entitled to have the Appliance repaired or replaced if the Appliance fails to be of acceptable quality and the failure does not amount to a major failure. 'Acceptable quality' and 'major failure' have the same meaning as referred to in the ACL.

10. New Zealand: For Appliances and services provided by Electrolux in New Zealand, the Appliances come with a guarantee by Electrolux pursuant to the provisions of the Consumer Guarantees Act, the Sale of Goods Act and the Fair Trading Act. Where the Appliance was purchased in New Zealand for commercial purposes the Consumer Guarantee Act does not apply.

11. Confidentiality: You accept that if you make a warranty claim, Electrolux and its agents including ASC may exchange information in relation to you to enable Electrolux to meet its obligations under this warranty.

Important Notice

Before calling for service, please ensure that the steps listed in clause 8 above have been followed.

AUSTRALIA	<p>FOR SERVICE or to find the address of your nearest authorised service centre in Australia PLEASE CALL 13 13 49 For the cost of a local call</p>	<p>FOR SPARE PARTS or to find the address of your nearest spare parts centre in Australia PLEASE CALL 13 13 50 For the cost of a local call</p>
NEW ZEALAND	<p>FOR SERVICE or to find the address of your nearest authorised service centre in New Zealand PLEASE CALL 0800 10 66 10</p>	<p>FOR SPARE PARTS or to find the address of your nearest spare parts centre in New Zealand PLEASE CALL 0800 10 66 20</p>

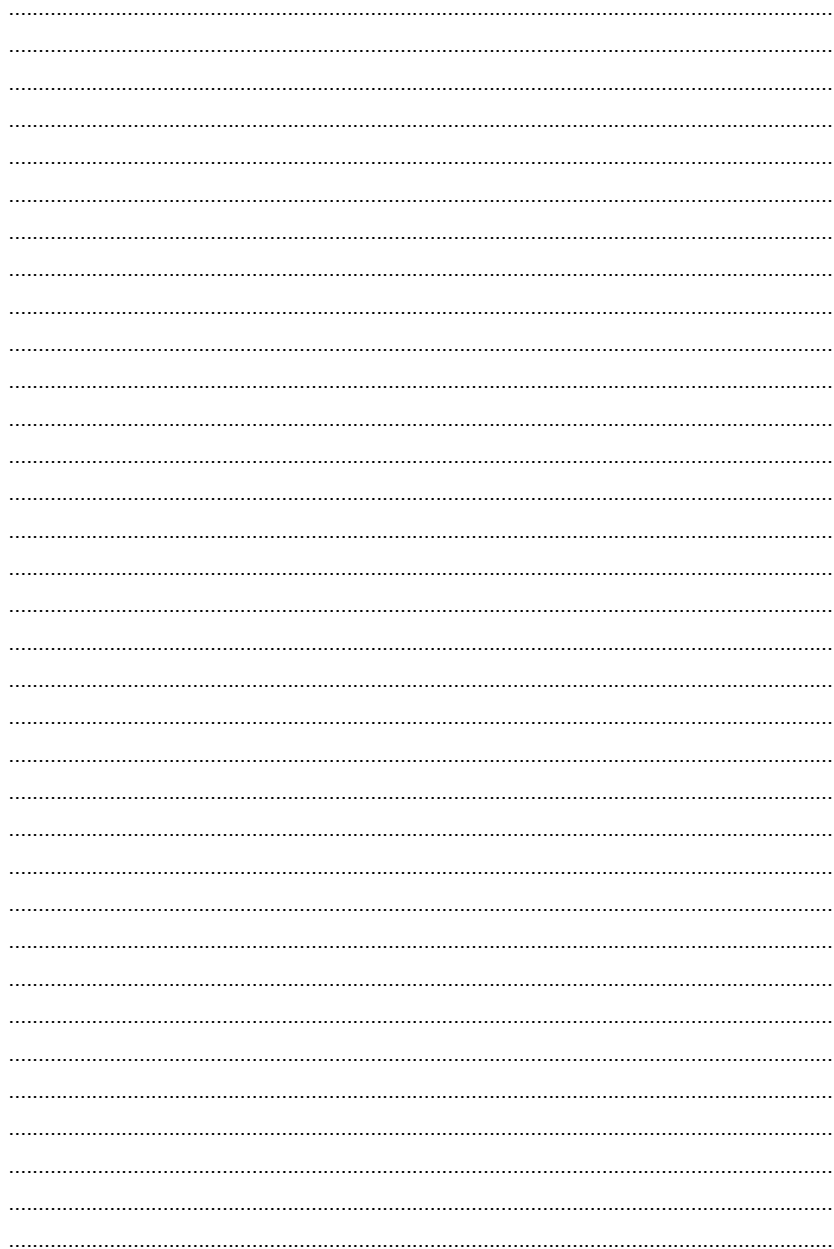

www.electrolux.com/shop



A30924501-B-222026

