

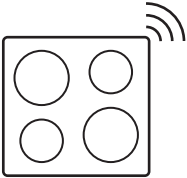

Electrolux



electrolux.com/register



EN User Manual | **Hob**

KIS8759



Important Information that may impact your Manufacturer's Warranty

Adherence to the directions for use in this manual is extremely important for health and safety. Failure to strictly adhere to the requirements in this manual may result in personal injury, property damage and affect your ability to make a claim under the Electrolux manufacturer's warranty provided with your product. Products must be used, installed and operated in accordance with this manual. You may not be able to claim on the Electrolux manufacturer's warranty in the event that your product fault is due to failure to adhere to this manual.

WELCOME TO ELECTROLUX! THANK YOU FOR CHOOSING OUR APPLIANCE.



Get usage advice, brochures, troubleshooting, service and repair information at www.electrolux.com



Register your product for better service: www.registerelectrolux.com

Subject to change without notice.

CONTENTS

1. SAFETY INFORMATION.....	2
2. SAFETY INSTRUCTIONS.....	5
3. INSTALLATION.....	7
4. PRODUCT DESCRIPTION.....	9
5. BEFORE FIRST USE.....	11
6. DAILY USE.....	12
7. HINTS AND TIPS.....	20
8. CARE AND CLEANING.....	21
9. TROUBLESHOOTING.....	22
10. TECHNICAL DATA.....	25
11. ENERGY EFFICIENCY.....	25
12. WARRANTY - AUSTRALIA AND NEW ZEALAND.....	26
13. ENVIRONMENTAL CONCERNS.....	28

1. ⚠ SAFETY INFORMATION

Before the installation and use of the appliance read the supplied instructions carefully. The manufacturer is not responsible for any injuries or damage that result from incorrect installation or usage. Always keep the instructions in a safe and accessible location for future reference.

1.1 Children and vulnerable people safety

- This appliance can be used by children aged from 8 years and above and persons with reduced physical, sensory or mental capabilities or lack of experience and knowledge if they have been given supervision or instruction concerning the use of the appliance in a safe way and understand the hazards involved. Children of less than 8 years of age and persons with very extensive and complex disabilities shall be kept away from the appliance unless continuously supervised.
- Children should be supervised to ensure that they do not play with the appliance and mobile devices with the dedicated app.
- Keep all packaging away from children and dispose of it appropriately.
- **WARNING:** The appliance and its accessible parts become hot during use. Keep children and pets away from the appliance when in use and when cooling down.
- If the appliance has a child safety device, it should be activated.
- Children shall not carry out cleaning and user maintenance of the appliance without supervision.

1.2 General Safety

- This appliance is for cooking purposes only.
- This appliance is designed for single household domestic use in an indoor environment.
- This appliance may be used in offices, hotel guest rooms, bed & breakfast guest rooms, farm guest houses and other similar accommodation where such use does not exceed (average) domestic usage levels.
- **WARNING:** The appliance and its accessible parts become hot during use. Care should be taken to avoid touching heating elements.
- **WARNING:** Unattended cooking on a hob with fat or oil can be dangerous and may result in fire.

- Smoke is an indication of overheating. Never use water to extinguish the cooking fire. Switch off the appliance and cover flames with e.g. a fire blanket or lid.
- **WARNING:** The appliance must not be supplied through an external switching device, such as a timer, or connected to a circuit that is regularly switched on and off by a utility.
- **CAUTION:** The cooking process has to be supervised (even the automatic cooking functions). A short term cooking process has to be supervised continuously.
- **WARNING:** Danger of fire: Do not store items on the cooking surfaces.
- Metallic objects such as knives, forks, spoons and lids should not be placed on the hob surface since they can get hot.
- Do not use the appliance before installing it in the built-in structure.
- Do not use water spray and steam to clean the appliance.
- After use, switch off the hob element by its control and do not rely on the pan detector.
- **WARNING:** If the surface is cracked, switch off the appliance to avoid the possibility of electric shock. In case the appliance is connected to the mains directly using junction box, remove the fuse to disconnect the appliance from power supply. In either case contact the Authorised Service Centre.
- If the supply cord is damaged, it must be replaced by the manufacturer, an authorized Service or similarly qualified persons in order to avoid a hazard.
- **WARNING:** Use only hob guards designed by the manufacturer of the cooking appliance or indicated by the manufacturer of the appliance in the instructions for use as suitable or hob guards incorporated in the appliance. The use of inappropriate guards can cause accidents.

2. SAFETY INSTRUCTIONS

2.1 Installation

 **WARNING!**

Only a qualified person must install this appliance.

 **WARNING!**

Risk of injury or damage to the appliance.

- Remove all the packaging.
- Do not install or use a damaged appliance.
- Follow the installation instructions supplied with the appliance.
- Keep the minimum distance from other appliances and units.
- Always take care when moving the appliance as it is heavy. Always use safety gloves and enclosed footwear.
- Seal the cut surfaces of the cabinet with a sealant to prevent moisture from causing swelling.
- Protect the bottom of the appliance from steam and moisture.
- Do not install the appliance next to a door or under a window. This prevents hot cookware from falling from the appliance when the door or the window is opened.
- Each appliance has cooling fans on the bottom.
- If the appliance is installed above a drawer:
 - Do not store any small pieces or sheets of paper that could be pulled in, as they can damage the cooling fans or impair the cooling system.
 - Keep a distance of minimum 2 cm between the bottom of the appliance and parts stored in the drawer.
- Remove any separator panels installed in the cabinet below the appliance.

2.2 Electrical connection

 **WARNING!**

Risk of fire and electric shock.

- All electrical connections should be made by a qualified electrician.

- The appliance must be earthed.
- Before carrying out any operation make sure that the appliance is disconnected from the power supply.
- Make sure that the parameters on the rating plate are compatible with the electrical ratings of the mains power supply.
- Make sure the appliance is installed correctly. Loose and incorrect electricity mains cable or plug (if applicable) can make the terminal become too hot.
- Use the correct electricity mains cable.
- Do not let the electricity mains cable tangle.
- Make sure that a shock protection is installed.
- Use the strain relief clamp on the cable.
- Make sure the mains cable or plug (if applicable) does not touch the hot appliance or hot cookware, when you connect the appliance to a socket.
- Do not use multi-plug adapters and extension cables.
- Make sure not to cause damage to the mains plug (if applicable) or to the mains cable. Contact our Authorised Service Centre or an electrician to change a damaged mains cable.
- The shock protection of live and insulated parts must be fastened in such a way that it cannot be removed without tools.
- Connect the mains plug to the mains socket only at the end of the installation. Make sure that there is access to the mains plug after the installation.
- If the mains socket is loose, do not connect the mains plug.
- Do not pull the mains cable to disconnect the appliance. Always pull the mains plug.
- Use only correct isolation devices: line protecting cut-outs, fuses (screw type fuses removed from the holder), earth leakage trips and contactors.
- The electrical installation must have an isolation device which lets you disconnect the appliance from the mains at all poles. The isolation device must have a contact opening width of minimum 3 mm.

- If the E3 code appears on the screen, immediately disconnect the hob and check if the electrical connection and the mains voltage are correct.

2.3 Use

 **WARNING!**

Risk of injury, burns and electric shock.

- Do not change the specification of this appliance.
- Remove all the packaging, labelling and protective film (if applicable) before first use.
- Make sure that the ventilation openings are not blocked.
- Do not let the appliance stay unattended during operation.
- Set the cooking zone to “off” after each use.
- Do not put cutlery or saucepan lids on the cooking zones. They can become hot.
- Do not operate the appliance with wet hands or when it comes in contact with water.
- Do not use the appliance as work surface and do not place food in direct contact with it.
- If the surface of the appliance is cracked, disconnect immediately the appliance from the power supply to prevent the electric shock.
- Users with a pacemaker must keep a distance of minimum 30 cm from the induction cooking zones when the appliance is in operation.
- When you place food into hot oil, it may splash.
- Do not use aluminum foil or other materials between the cooking surface and the cookware, unless otherwise specified by the manufacturer of this appliance.
- Use only accessories recommended for this appliance by the manufacturer.

 **WARNING!**

Risk of fire and explosion.

- Fats and oils when heated can release flammable vapours. Keep flames or

heated objects away from fats and oils when you cook with them.

- The vapours that hot oil releases can cause spontaneous combustion.
- Used oil, that can contain food remnants, can cause fire at a lower temperature than oil used for the first time.
- Do not put flammable products or items moistened with flammable products in, near or on the appliance.

 **WARNING!**

Risk of damage to the appliance.

- Do not keep hot cookware on the control panel to avoid the risk of burns.
- Do not put a hot pan cover on the glass surface of the hob.
- Do not let cookware boil dry.
- Be careful not to let objects or cookware fall on the appliance. The surface can be damaged.
- Do not activate the cooking zones with empty cookware or without cookware.
- Cookware made of cast iron or with a damaged bottom can cause scratches on the glass / glass ceramic. Always lift these objects up when you have to move them on the cooking surface.

2.4 Food sensor

 **WARNING!**

Risk of injury and burns.

- Use the Food sensor according to its purpose. Do not use it to open or lift anything.
- Use only the Food sensor recommended for the hob, one at a time.
- Do not use it when it is malfunctioning or damaged.
- Do not use the Food sensor in the oven or microwave.
- Make sure that the Food sensor is always inside the food or liquid, up to the minimum level mark.
- Clean the Food sensor before and after each use. Be careful, the tip of the Food sensor is pointed.
- Use only neutral detergents. Do not use any abrasive products, abrasive cleaning pads, solvents or metal objects. Do not

wash the Food sensor in the dishwasher. The silicone handle may discolour, which has no effect on how the Food sensor operates.

- Use the original packaging to store and charge the Food sensor.
- Make sure that the Food sensor is cool, clean, and dry before placing it into the charger.
- Store the Food sensor in a safe, dry place out of the reach of children.

2.5 Care and cleaning

- Clean the appliance regularly to prevent the deterioration of the surface material.
- Switch off the appliance and let it cool down before cleaning.
- Clean the appliance with a moist soft cloth. Use only neutral detergents. Do not use abrasive products, abrasive cleaning pads, solvents or metal objects, unless otherwise specified.

2.6 Service

- To repair the appliance contact the Authorised Service Centre. Use original spare parts only.

- Concerning the lamp(s) inside this product and spare part lamps sold separately: These lamps are intended to withstand extreme physical conditions in household appliances, such as temperature, vibration, humidity, or are intended to signal information about the operational status of the appliance. They are not intended to be used in other applications and are not suitable for household room illumination.

2.7 Disposal

WARNING!

Risk of injury or suffocation.

- Contact your local authority for information on how to dispose of the appliance.
- Disconnect the appliance from the mains supply.
- Cut off the mains electrical cable close to the appliance and dispose of it.

3. INSTALLATION

WARNING!

Refer to Safety chapters.

3.1 Before the installation

Before you install the hob, write down the information below from the rating plate. The rating plate is on the bottom of the hob.

Serial number

3.2 Built-in hobs

Only use the built-in hobs after you assemble the hob into correct built-in units and work surfaces that align to the standards.

3.3 Connection cable

- The hob is supplied with a connection cable.

- To replace the damaged mains cable, use the cable type: H05V2V2-F which withstands a temperature of 90 °C or higher. A single wire must have a minimal cross section in accordance with the table below. Speak to your local Service Centre. The connection cable may only be replaced by a qualified electrician.

WARNING!

All electrical connections must be made by a qualified electrician.

CAUTION!

Connections via contact plugs are forbidden.

⚠ CAUTION!

Do not drill or solder the wire ends. It is forbidden.

⚠ CAUTION!

Do not connect the cable without cable end sleeve.

Two-phase connection: 400 V2N~

5x1,5 mm² or 4x2,5 mm²

	Green - yellow
N	Blue and blue
L1	Black
L2	Brown

One-phase connection:

5x1,5 mm² or 3x4 mm²

Green - yellow	
Blue and blue	N
Black and brown	L

3.4 Assembly

If you install the hob under a hood, please see the installation instructions of the hood for the minimum distance between the appliances.

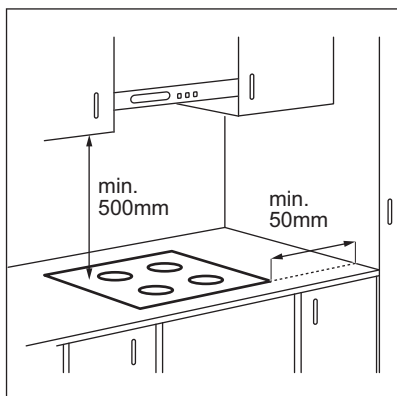

If the appliance is installed above a drawer, the hob ventilation can warm up the items stored in the drawer during the cooking process.

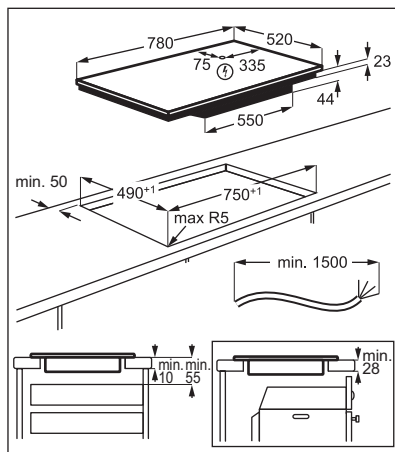

Find the video tutorial "How to install your Electrolux Induction Hob - Worktop installation" by typing out the full name indicated in the graphic below.



www.youtube.com/electrolux
www.youtube.com/aeg

How to install your Electrolux Induction Hob - Worktop installation



4. PRODUCT DESCRIPTION

4.1 Cooking surface layout

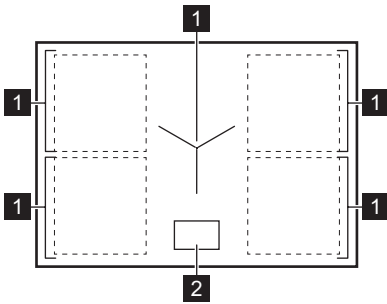

1 Induction cooking zone

2 Control panel



For detailed information on the sizes of the cooking zones refer to "Technical data".

4.2 Control panel layout

Main view

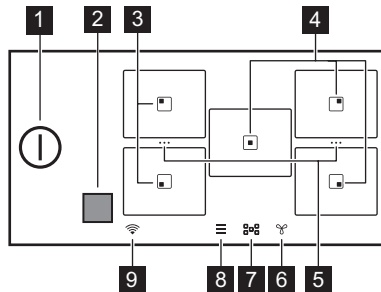







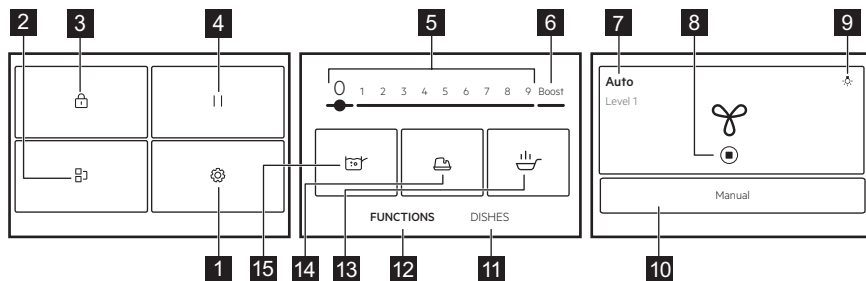

Symbol	Description
1	To activate and deactivate the hob.
2	Window of the Hob²Hood infrared signal communicator. Do not cover it.
3	Zone with Pan-frying and Boiling functions.
4	Zone with Boiling function.
5 ...	A shortcut for Bridge. To merge two side cooking zones to create one cooking area or to split the merged zones.
6	To set the hood functions.
7	To open the zone overview.
8	To open the Menu.

Symbol	Description
9 	The WiFi indicator.

Expanded view



The list of functions may vary depending on the software version.

Symbol	Description
1 	Settings. To open the settings of the hob.
2 	Bridge. To connect two side cooking zones so that they operate as one.
3 	Lock. To lock / unlock the control panel.
4 	Pause. To set all cooking zones that operate to the lowest heat setting.
5 1 - 9	To set a heat setting.
6 Boost	To activate the maximum heat setting.
7 Manual / Auto	To show the current setting of the hood fan.
8 	To stop / restart the hood.
9 	To turn the hood light on or off.
10 Manual / Auto	To switch to the manual or auto mode of the hood.
11 Dishes	To select preset automatic programs for different types of food.
12 FUNCTIONS	To select automatic programs for different methods of cooking.
13 	Pan-frying. To fry with automatically controlled heat levels, dedicated to various types of food.
14 	Melting. To melt different products, e.g. chocolate or butter.
15 	Boiling. To automatically adjust the temperature of water so that it does not boil over once it reaches the boiling point.

Display navigation

Symbol	Description
OK	To confirm the selection or setting.
X	To close the pop-up window.
^ v	To collapse / expand the instructions on the display.
☐	To activate / deactivate the option.
< >	To go back / forward one level in the Menu.

5. BEFORE FIRST USE

⚠ WARNING!

Refer to Safety chapters.

5.1 Navigating the display

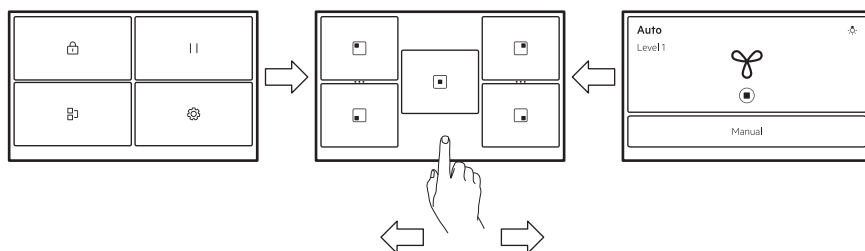

To navigate between the screens, tap on the symbols on the bottom of the display. You can also swipe to the left to manage the settings for Hob²Hood or to the right to reach the Menu.



If the display does not immediately react, make sure you are touching the centre of the chosen symbol / option or try to press it a bit longer.

5.2 First connection to the mains

When you connect the hob to the mains you have to set Language, Brightness, Volume and Key tones.

You can change the setting in Menu > Settings > Setup. Refer to "Daily use".

5.3 FlexPower - FOR INSTALLER ONLY

FlexPower defines how much power is used by the hob in total, within the limits of the house installation fuses.

Originally the appliance works at the highest possible power level. You can change the maximum power if the installation does not support the full power. **If you want to**

change the default setting, contact the Authorised Service Centre first.

⚠ CAUTION!

The hob is intended for installation at the highest power (7350 W). Ensure your home electrical wiring can support the maximum power setting before installation. Installation shall comply with AS/NZS 3000 Wiring Rules.



If the power level is lower than 2000 W, you cannot activate any automatic programs (Dishes or FUNCTIONS).

1. Switch on the hob.
2. Make sure that all cooking zones are deactivated.
3. Touch on the display to open the Menu.
4. Select Settings > Setup > FlexPower and choose the appropriate power level.
5. Touch or . Follow the instructions on the display to confirm your selection.

⚠ CAUTION!

Make sure that the selected power fits the house installation fuses.

5.4 Wireless / app connection

In order to use the app the hob has to be connected to the wireless network. WiFi is on by default.

1. Touch .
2. Select Settings > Connections > WiFi.
3. Touch to activate WiFi.
The hob is now ready to connect to the wireless network and with the app.
4. Touch CONNECT.
5. Download the app. Scan the QR code located on the back cover of the user manual or download the app directly from the app store.
6. Open the app and register to get an account.
7. Add a new appliance.
8. Follow the instructions in the app to complete the connection process.

Changing / deactivating the network connection

To disconnect the hob from your home network:

1. Touch .
2. Select Settings > Connections > WiFi:
 - To disconnect from your wireless network touch DISCONNECT.
 - To deactivate WiFi touch .

To connect the hob to the new wireless network refer to "Wireless / app connection" above.

6. DAILY USE

⚠ WARNING!

Refer to Safety chapters.

6.1 Activating and deactivating

Touch for 1 second to activate or deactivate the hob.

6.2 Automatic Switch Off

The function deactivates the hob automatically if:

- all cooking zones are deactivated.
- you do not set the heat setting after you activate the hob.
- you spill or put something on the control panel for more than 10 seconds (a pan, a cloth, etc.). An acoustic signal sounds and the hob deactivates. Remove the object or clean the control panel.
- the hob gets too hot (e.g. when a saucepan boils dry). Let the cooking zone cool down before you use the hob again.
- you use incorrect cookware or there is no cookware on a given zone. The induction

cooking zone deactivates automatically after 50 seconds.

- you do not deactivate a cooking zone or change the heat setting. After some time a message comes on and the hob deactivates.

The relation between the heat setting and the time after which the hob deactivates:

Heat setting	The hob deactivates after
1 - 2	6 hours
3 - 5	5 hours
6	4 hours
7 - 9	1.5 hour



When you use Pan-frying the hob deactivates after 1.5 hours. For Melting the hob deactivates after 6 hours.

6.3 Pot detection

This feature detects if pots were placed on the cooking zones and deactivates the cooking zones if the cookware is no longer detectable.

- If you put cookware on a cooking zone first and then activate the hob, a grey bar appears on the overview of the corresponding cooking zone.
- The bar will not appear if there is no cookware on the cooking zone or the cookware cannot be detected due to its incorrect placement or unsuitable material.
- If you remove the cookware from an activated cooking zone and set it aside temporarily, the corresponding cooking zone overview will start blinking. If you do not place the cookware back on the activated cooking zone within 120 seconds, the cooking zone will automatically deactivate. To resume cooking, make sure to put the cookware back on the cooking zones before the indicated timeout.

6.4 Using the cooking zones

Induction cooking zones adapt to the dimensions of the bottom of the cookware automatically.



For optimal heat transfer use cookware with bottom diameter similar to the size of the cooking zone (i.e. the maximum cookware diameter value in "Technical data" > "Cooking zones specification"). Make sure that the cookware is suitable for induction hobs. For more information on cookware types refer to "Hints and tips".

To activate the cooking zone place the cookware in the centre of the cooking zone and touch the relevant zone symbol. The available programs appear on the display. Set the heat level or select one of the automatic functions. To get back to the main view touch **X** in the top right corner.

You can cook with large cookware placed on two cooking zones at the same time using Bridge.

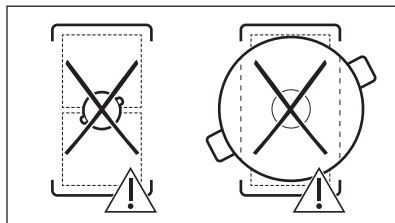
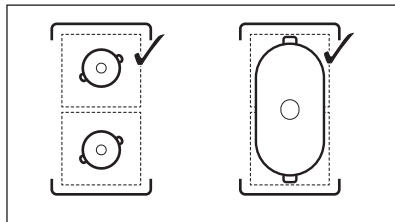

When other cooking zones are active the heat setting for the zone you want to use may be limited. Refer to "Power management".

6.5 Heat setting

1. Activate the hob.
2. Place the pot on the selected cooking zone and touch the relevant zone symbol.
3. Touch or slide your finger to set the heat setting.

The power level icons 1-9 become bigger and the bar below turns red to indicate the current power setting. When the power level is selected the screen changes to the expanded screen view.

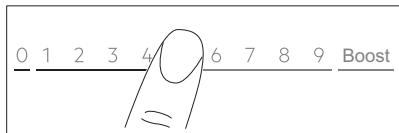

You can also change the heat setting on the zone overview screen. To go to the zone overview screen, touch the centre of the expanded screen view. To change the heat level touch or . To open the expanded screen view, touch the power level.

6.6 Boost

This function makes more power available to the induction cooking zones. The function can be activated for the cooking zone only for a limited time. After this time the cooking zone automatically goes back to the highest heat setting.

1. Select the cooking zone.
2. Touch Boost to activate the function. The function deactivates automatically. To deactivate the function manually select the zone and change its heat setting to 0.

Boost does not work when:

- Bridge operates,
- the power within one phase is insufficient (refer to "Power management").

For maximum duration values, refer to "Technical data".

6.7 OptiHeat Control (3 step Residual heat indicator)

WARNING!

As long as the indicator is on, there is a risk of burns from residual heat.

The induction cooking zones produce the heat necessary for the cooking process directly in the bottom of the cookware. The glass ceramic is heated by the heat of the cookware.

The indicators appear when a cooking zone is hot. They show the level of the residual heat for the cooking zones you are currently using:

- continue cooking,

- keep warm,

- residual heat.

The indicator may also appear:

- for the neighbouring cooking zones even if you are not using them,
- when hot cookware is placed on a cold cooking zone,
- when the hob is deactivated but the cooking zone is still hot.

The indicator disappears when the cooking zone has cooled down.

6.8 Keep Warm mode

This function keeps food warm with the low temperature setting.

Keep Warm mode is available only when the cooking zone is still warm after the finished cooking process (with a visible residual heat icon) and the cookware remains on the zone. The function does not work with a cold cooking zone.

1. Touch to activate the Keep Warm mode.

The Keep Warm mode operates until turned off.

2. To stop the function touch in the upper left corner of the display.

You can set a timer, if needed. Refer to "Timer options".

6.9 Timer options

ECO Timer

Use this function to specify how long a cooking zone should operate during a single cooking session.

To save energy, the heater of the cooking zone deactivates before the ECO Timer sounds. The difference in the operation time depends on the heat setting level and the length of the cooking operation.

You can use this function when the cooking zone is activated. You can set the function for each cooking zone separately.

1. Set the heat setting for the appropriate cooking zone first and then set the function.
2. Touch the zone symbol.
3. Touch .

The timer menu window appears on the display.

4. Tick the Stop zone box to activate the function.
5. Set the time.
6. Touch OK to confirm.

You can also choose **X** to cancel your selection.

You can change the ECO Timer settings during cooking: touch  with the timer value, then touch EDIT.

When the timer runs out, a signal sounds and a pop-up window appears. Touch OK to stop the signal.

To deactivate the function, set the heat setting to **0**. Alternatively, touch  with the timer value, touch **X** and confirm your choice when a pop-up window appears.

Timer

You can use this function when the cooking zone is activated.

The function has no effect on any other function operating concurrently.

1. Select any cooking zone.
The relevant slider appears on the display.

2. Touch .

The timer menu window appears on the display.

3. Untick the Stop zone box to activate the function.
4. Set the time.
5. Touch OK to confirm.

You can also choose **X** to cancel your selection.

You can change the Timer settings during cooking: touch  with the timer value, then touch EDIT.

When the timer runs out, a signal sounds and a pop-up window appears. Touch OK to stop the signal.

To deactivate the function touch  with the timer value, touch **X** and confirm your choice when a pop-up window appears.

6.10 / ... Bridge

The function connects two cooking zones and they operate as one with the same heat setting. You can use it to cook with large cookware.

Cookware must cover the centres of both zones. If the cookware is located between the two centres, the function will not be activated.

1. Place the cookware on the cooking zones.
2. Touch  >Bridge. You can also use the shortcut **...** visible in the zone overview.
3. Set the heat setting.

To deactivate the function, touch the shortcut **...**. The cooking zones resume operating independently.



6.11 Pause

This function sets all cooking zones that operate to the lowest heat setting.

You cannot activate the function if any automatic program (Dishes or FUNCTIONS) is running.

When the function operates only  and RESUME can be used. All other symbols on the control panel are locked.

The function does not stop the timer functions. When the timer function ends, tap anywhere on the screen to stop the acoustic signal.

1. Touch  to open the Menu.
2. Touch  to activate the function.



The heat setting is lowered to  (Keep Warm mode) and the fan speed level in Manual mode is lowered to 1.

To deactivate the function touch RESUME.

The previous heat settings will be restored.

6.12 Lock

You can lock the control panel while the hob operates. It prevents an accidental change of the heat setting.

1. Set the heat setting.
2. Touch  to open the Menu.
3. Touch  to activate the function.

To deactivate the function, press and hold UNLOCK for 4 seconds.



When you deactivate the hob, you also deactivate this function.

6.13 Child lock

This function prevents an accidental operation of the hob.

1. Touch  to open the Menu.
2. Select Settings > Options > Child lock.
3. Turn the switch on and touch the letters E-U-O in the alphabetical order to activate the function.

To deactivate the function turn the switch off.

It may take some time for the function to work after activation.

6.14 FUNCTIONS: Pan-frying

This function lets you set an appropriate heat setting level to fry your food. The hob adjusts the temperature to different types of food and maintains it throughout cooking. Once the heat setting level is set, no manual temperature adjustment is necessary.

CAUTION!

Use only cold cookware.
Do not leave the hob unattended while the function is operating.

1. Place a pan without oil / fat on one of the cooking zones on the left side.
2. Select FUNCTIONS > Pan-frying.
3. Choose a frying level.

Preheating starts.

4. Set a timer function, if needed.

The timer starts immediately.

Once the pan reaches the intended temperature an acoustic signal sounds and a pop-up window appears. You can put oil and food inside the pan now. To close the window and start frying touch OK. To stop the function manually touch 0 on the control bar.

Hints and tips:

- Follow the instructions on the display for when to flip the food over or to adjust the heat level.
- You can change the default heat level, if needed.
- For thick pieces of food or raw potatoes use a lid during the first 10 min of frying.
- Heavy pans may take longer to heat-up.
- Use laminated pans with low heat level to prevent overheating and damage of the cookware.
- Do not use thin enamelled cookware. It can be overheated and damaged.

Correct pans for Pan-frying function

Use only pans with flat bottoms. To check if the pan is correct:

1. Put your pan upside down.
2. Put a ruler on the bottom of the pan.
3. Try to put a coin of 1, 2, or 5 Euro Cent (or any coin with similar thickness, approx. 1.7 mm) between the ruler and the bottom of the pan.

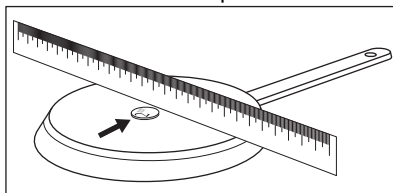

- a. The pan is incorrect if you can put the coin between the ruler and the pan.

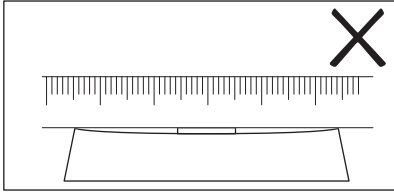

- b. The pan is correct if you cannot put the coin between the ruler and the pan.

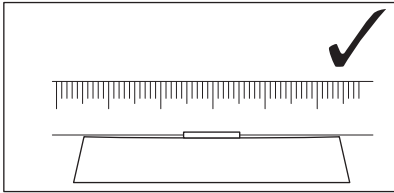

6.15 FUNCTIONS: Boiling

This function adjusts the heat setting level automatically so that water does not boil over once it reaches the boiling point.



The function is available on all cooking zones. If there is any residual heat (I / II / III) on the cooking zone you want to use, the function is disabled. Wait until the zone cools down to use the function. The function does not work with non-stick cookware.



CAUTION!

Do not use the function with empty cookware. Do not leave the hob unattended while the function is operating.

1. Place a pot filled with at least 1 l of water on the cooking zone.
2. Select FUNCTIONS > Boiling.
3. Set a timer function, if needed. The timer starts immediately.
4. To stop the function manually touch  in the upper left corner of the display.

Once the boiling point has been reached, the hob automatically reduces the heat setting level. At this point you can also adjust it manually as needed.

Hints and tips:

- The function is best suited for boiling water and cooking potatoes.
- The function may not work properly for kettles and stovetop espresso pots.
- Fill between half to three quarters of the pot with cold tap water leaving 4 cm from the rim of the pot empty. Do not use less than 1 or more than 5 litres of water. Make sure the total weight of the water (or the water and potatoes) ranges between 1-5 kg.

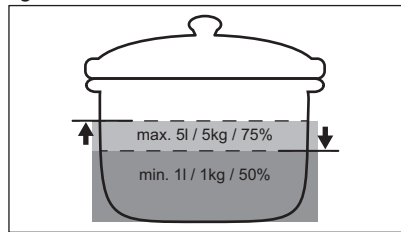

- To achieve the best results cook only whole, unpeeled, medium-sized potatoes. Make sure you do not pack potatoes too tightly.
- Avoid producing external vibrations (e.g. from using a blender or placing a mobile phone next to the hob) when the function is running.
- Depending on the type of food and cookware you can adjust the heat setting after the boiling point has been reached.
- Add salt once the boiling point has been reached.
- Use a lid to save energy.

6.16 FUNCTIONS: Melting

You can use this function to melt products, e.g. chocolate or butter.



CAUTION!

Do not leave the hob unattended while the function is operating.

1. Place cookware on the cooking zone.
2. Select FUNCTIONS > Melting.
3. Set a timer function, if needed.
4. Touch OK.

To stop the function manually touch  in the upper left corner of the display.

6.17 Dishes



This function helps you prepare different foods using preset programs dedicated to specific food categories. The availability of programs depends on the cooking zone.

CAUTION!

Do not leave the hob unattended while the function is operating.

- Place cookware on the cooking zone.
You can use a single cooking zone or connect two side zones using Bridge.
 - Select Dishes.
 - Select the food type.
 - Set a timer function, if needed.
 - Follow the instructions on the display.
- Depending on the food type and the selected program you can set and modify details, e.g. level of doneness, level of heat for frying, etc.

Hints and tips:

- The most often cooked dishes are automatically added to the list of Most cooked.
- You can manually add programs to the list of Favourites .
- You can hide certain programs by touching . To restore the programs, go to Settings > Setup > Dishes.

6.18 Hob²Hood

It is an automatic function which connects the hob to a suitable hood. Both the hob and the hood have an infrared signal communicator. The speed of the fan is defined and adjusted automatically based on the mode setting and the temperature of the hottest cookware on the hob. You can also operate the fan manually from the hob or the hood itself.





If you change the fan speed on the hood, the default connection with the hob will be deactivated. To reactivate the function, turn both appliances off and on again.







In some hoods the function might be disabled by default. In such cases, activate the function first on the hood, then on the hob. For more information refer to the hood user manual.

Setting the automatic fan mode

To set the hood to an automatic mode, choose between the following set fan speeds: Mode 2 - Mode 6. The hood reacts whenever you operate the hob. You can set the hob to activate only the light by selecting Mode 1.

- Touch .
- Select Settings > Hob²Hood.
- Turn a switch on to activate the hood.
All automatic modes appear as a list.
- Choose the mode.
- Touch  or  to save the selection and leave.

To check the current fan speed level, touch . The fan speed level is visible in the top left corner of the display. To turn off the fan, touch . To turn on the fan, touch .

Automatic modes	Auto- matic light	Boiling ¹⁾	Frying ²⁾
		Fan speed	
 OFF	Off	-	-
Mode 1	On	-	-
Mode 2 ³⁾	On	1	1
Mode 3	On	-	1
Mode 4	On	1	1
Mode 5	On	1	2
Mode 6	On	2	3

- The hob detects the boiling process and sets fan speed in accordance with the automatic mode.
- The hob detects the frying process and sets fan speed in accordance with the automatic mode.
- This mode activates the fan and the light and does not rely on the temperature.

Setting the manual fan mode

You can adjust the fan speed level manually.

1. Touch .

2. Touch Manual.

A control bar appears with the current fan speed.

3. Touch or slide your finger to set the fan speed level.

To activate the maximum fan speed level touch Boost. The fan runs in Boost mode for a certain time. After that time the fan speed level automatically changes to 3. To deactivate Boost manually, press 0.

Hood light

You can set the hob to activate the light automatically whenever you activate the hob. To do so, set the automatic mode to Mode 1 - Mode 6. You can also manually activate or deactivate the light on the hood.

Activating the light manually

1. Touch .

2. Touch  to turn on the light.



To turn off the light touch  again.



6.19 Language

1. Touch  to open the Menu.

2. Select Settings > Setup > Language.

3. Choose the language from the list.

To save the selection touch  or . Then choose YES in the pop-up window.

If you chose the wrong language, touch  > . A list appears. Select the first option from the top on the left, then the first option from the top on the left (alternatively, the second option from the top on the right, depending on the software version). Scroll down to choose the correct language from the list. When the pop-up window appears, choose the option on the right.

6.20 Key tones / Volume

You can choose the type of sound your hob emits or turn the sounds off entirely. You can choose between the click (default) or beep.

You can also choose the volume level.

1. Touch  on the display to open the Menu.

2. Select Settings > Setup > Key tones / Volume.

3. Choose the appropriate option.

The setting is saved automatically.

6.21 Brightness

You can change the brightness of the display.

There are 5 brightness levels, 1 is the lowest and 5 is the highest.

1. Touch  to open the Menu.

2. Select Settings > Setup > Brightness.

3. Choose the appropriate level.

The setting is saved automatically.

6.22 Power management

If multiple zones are active and the consumed power exceeds the limitation of the power supply, this function divides the available power between all cooking zones (connected to the same phase). The hob controls heat settings to protect the fuses of the house installation.

- If the hob reaches the limit of maximum available power (refer to the rating plate), the power of the cooking zones will be automatically reduced.
- The heat setting of the cooking zone selected first (or a cooking zone using FUNCTIONS or Dishes) is always prioritised. The remaining power will be divided between the other cooking zones according to the order of selection.
- The colour of the control bar shows the available heat setting options:
 - red - the current heat setting,
 - white - the maximum available heat setting,
 - light grey - the unavailable heat setting (Power management operates).
- If a higher heat setting is not available reduce it for the other cooking zones first.

If total power of the hob is limited (1500 W - 6000 W) the function distributes the available power between all cooking zones. Refer to chapter "Before first use" > "FlexPower".

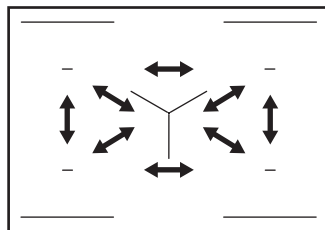

7. HINTS AND TIPS

WARNING!

Refer to Safety chapters.

7.1 Cookware

i

For induction cooking zones a strong electro-magnetic field creates the heat in the cookware very quickly.

Use the induction cooking zones with suitable cookware.

- To prevent overheating and improve the performance of the zones, the cookware must be as thick and flat as possible.
- For Pan-frying function only use pans with flat bottom.
- Ensure cookware bases are clean and dry before placing on the hob surface.
- Always be careful no to slide or rub the cookware on the edges and corners of the glass as it may chip or damage the glass surface.

Cookware material

- **correct:** cast iron, steel, enamelled steel, stainless steel, multi-layer bottom (with a correct marking from a manufacturer).
- **not correct:** aluminium, copper, brass, glass, ceramic, porcelain.

Cookware is suitable for an induction hob if:

- water boils very quickly on a zone set to the highest heat setting.

- a magnet pulls on to the bottom of the cookware.

Cookware dimensions

- Induction cooking zones adapt to the dimension of the bottom of the cookware automatically. Refer to "Technical data" > "Cooking zones specification" for correct cookware dimensions. Place the cookware in the centre of the selected cooking zone.
- The efficiency of a cooking zone is related to the diameter of the cookware. For optimal heat transfer use cookware with bottom diameter similar to the size of the cooking zone (i.e. the maximum cookware diameter value in "Technical data" > "Cooking zones specification").
 - Cookware with a diameter smaller than the size of a given cooking zone receives only part of the power generated by the cooking zone which results in slower heating.
 - For both safety reasons and optimal cooking results, do not use cookware larger than indicated in "Cooking zones specification". Avoid keeping cookware close to the control panel during the cooking session. This might impact the functioning of the control panel or accidentally activate hob functions.

i

Refer to "Technical data".

7.2 Noises during operation



The noises are normal and do not indicate any malfunction. Cookware noises may vary depending on the cookware material and the power level.

Cookware-related noises:

- cracking noise: cookware is made of different materials (a sandwich construction).
- whistling sound: you use a cooking zone with a high power level and the cookware is made of different materials (a sandwich construction).
- humming: you use a high power level.

Hob-related noises:

- clicking: electric switching occurs, cookware is detected after you place it on the hob.
- hissing, buzzing: the fan operates.
- rhythmic sound: cookware is detected.

7.3 Hints and tips for Hob²Hood

When you operate the hob with the function:

- Protect the hood panel from direct sunlight.
- Do not spot halogen light on the hood panel.
- Do not cover the hob control panel.
- Do not interrupt the signal between the hob and the hood (e.g. with the hand, a cookware handle or a tall pot). See the picture.

The hood pictured below is for illustration purpose only.

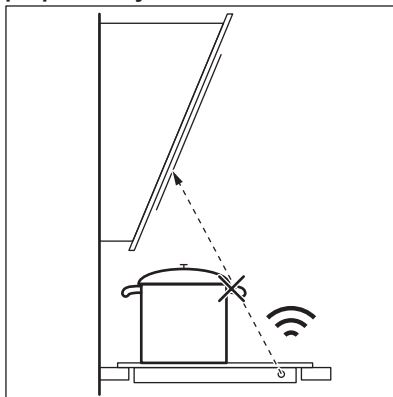

Keep the window of the Hob²Hood infrared signal communicator clean.



Other remotely controlled appliances may block the signal. Do not use any such appliances near to the hob while Hob²Hood is on.

Cooker hoods with the Hob²Hood function

To find the full range of cooker hoods which work with this function refer to our consumer website. The Electrolux cooker hoods that work with this function must have the symbol .

8. CARE AND CLEANING

WARNING!

Refer to Safety chapters.

8.1 General information

- Clean the hob after each use.
- Always use cookware with a clean base.
- Scratches or dark stains on the surface have no effect on how the hob operates.
- Use a special cleaning agent suitable for the surface of the hob.

- Always use a scraper recommended for hobs with a glass surface. Use the scraper only as an additional tool for cleaning the glass after the standard cleaning procedure.



WARNING!

Do not use knives or any other sharp, metal tools to clean the glass surface.

8.2 Cleaning the hob

- **Remove immediately:** melted plastic, plastic foil, salt, sugar and food with sugar, otherwise, the dirt can cause damage to the hob. Take care to avoid burns. Use a special hob scraper on the glass surface at an acute angle and move the blade on the surface.
- **Remove when the hob is sufficiently cool:** limescale rings, water rings, fat

stains, shiny metallic discoloration. Clean the hob with a moist cloth and a non-abrasive detergent. After cleaning, wipe the hob dry with a soft cloth.

- **Remove shiny metallic discoloration:** use a solution of water with vinegar and clean the glass surface with a cloth.





9. TROUBLESHOOTING

WARNING!

Refer to Safety chapters.

9.1 What to do if...

Problem	Possible cause	Remedy
You cannot activate or operate the hob.	The hob is not connected to an electrical supply or it is connected incorrectly.	Check if the hob is correctly connected to the electrical supply. Refer to the connection diagram.
	The fuse is blown.	Make sure that the fuse is the cause of the malfunction. If the fuse is blown again and again, contact a qualified electrician.
	You did not set the heat setting for 60 seconds.	Activate the hob again and set the heat setting in less than 60 seconds.
	You touched 2 or more sensor fields at the same time.	Touch only one sensor field.
The display does not react to the touch.	Pause operates.	Refer to "Daily use".
	Part of the display is covered or the pots are placed too near to the display. There is some liquid or an object on the display.	Remove the objects. Move the pots away from the display. Clean the display, wait until the appliance is cold. Disconnect the hob from the electrical supply. After 1 min, connect the hob again.
An acoustic signal sounds and the hob deactivates. An acoustic signal sounds when the hob is deactivated.	You put something on one or more sensor fields.	Remove the object from the sensor fields.
The hob deactivates.	You put something on the sensor field ①.	Remove the object from the sensor field.
Residual heat indicator does not come on.	The zone is not hot because it operated only for a short time or the sensor under the hob surface is damaged.	If the zone operated sufficiently long to be hot, speak to an Authorised Service Centre.

Problem	Possible cause	Remedy
You cannot activate the highest heat setting.	Another zone is already set to the highest heat setting.	First reduce the power of the other zone.
	The FlexPower level is too low.	Change the maximum power in the Menu. Refer to "Before first use".
The sensor fields become hot.	The cookware is too large or you put it too near to the controls.	Put large cookware on the rear zones, if possible.
Hob ² Hood does not work.	You covered the control panel.	Remove the object from the control panel.
Hob ² Hood screen is not visible.	Hob ² Hood is turned off in the settings.	Go to settings/Hob ² Hood and activate the function.
Hob ² Hood operates, but only the light is on.	You activated Mode 1.	Change the mode to Mode 1 - Mode 6 or wait until the automatic mode starts.
Hob ² Hood Modes 1 - 6 operate, but the light is off.	There might be a problem with the light bulb.	Contact an Authorised Service Centre.
There is no sound when you touch the panel sensor fields.	The sounds are deactivated.	Activate the sounds. Refer to "Daily use".
Wrong language was set.	You changed the language by mistake.	Follow the instruction in "Daily use", "Language" to change the wrong language.
A cooking zone deactivates.	Automatic Switch Off deactivates the cooking zone.	Deactivate the hob and activate it again. Refer to "Daily use".
 and a message come on.	Lock operates.	Refer to "Daily use".
E - U - O appears.	Child lock operates.	Refer to "Daily use".
The power level bar blinks.	There is no cookware on the zone.	Put cookware on the zone.
	The cookware is unsuitable.	Use suitable cookware. Refer to "Hints and tips".
 comes on.	The diameter of the bottom of the cookware is too small for the zone.	Use cookware with correct dimensions. Refer to "Technical data".
	The electrical connection is faulty.	Disconnect the hob from the mains and check the connection. Refer to "Installation".
 comes on.	The zone temperature sensor detects a too high or too low temperature.	Let the cooking zone cool down or raise the ambient temperature above 15°C. If the problem persists, contact the Authorised Service Centre.
 comes on.	The cooling fan is blocked.	Make sure that nothing is blocking the fan. If the fan is not blocked by anything and the problem persists, contact the Authorised Service Centre.

Problem	Possible cause	Remedy
You can hear a constant beep noise.	The electrical connection is incorrect.	Disconnect the hob from the electrical supply. Ask a qualified electrician to check the installation.
Cookware heats up longer than 5 min.	The bottom of the cookware is not induction compatible.	Use cookware with a suitable bottom (flat, magnetic). Refer to "Hints and tips".
Heating up takes a long time.	Cookware is too small and receives only a part of the power generated by the cooking zone.	For optimal heat transfer use cookware with bottom diameter similar to the size of the cooking zone (i.e. the maximum cookware diameter value in "Technical data" > "Cooking zones specification").
Hob cannot connect to the wireless network.	The router blocks new WLAN participants.	Make sure that the router allows new participants. Restart the router, if needed.
	The wireless connection in the hob is not activated.	Activate the WiFi. Refer to "Before first use", Wireless / app connection.
	The frequency of the router is set to 5 GHz.	Change the settings of the router to 2,4 GHz or 2,4+5 GHz. If the router supports only 5 GHz frequency, the hob cannot be connected.
	The wireless network signal is weak.	Move the router closer to the hob. Use a WiFi repeater to boost the signal, if needed.
You cannot find the hob in the WLAN network list in the app settings.	The hob is already linked to the network but might not be visible.	Disconnect the hob from the network. Refer to "Before first use", Wireless / app connection.
A higher heat setting is not available.	Power management operates and reduces the maximum power.	Refer to "Daily use", Power management.
Boiling function does not start.	Residual heat is still active on this zone.	Wait until the zone cools off or use another, cold zone.
Boiling function does not stop.	There might not be enough water in the pot (vibrations cannot be detected) or the water is already too warm.	Use a minimum of 1 l of cold water per pot.
Boiling function stops suddenly.	The cookware is incompatible with the function. The function cannot detect vibrations made by the boiling water. The cookware might be too small for the cooking zone.	Do not use non-stick cookware with this function. Boil more water or switch to a cold zone. Do not add salt before water reaches the boiling point. Make sure the diameter of the cookware fits the size of the cooking zone. Place the cookware in the centre of the cooking zone.
Heating up with Pan-frying function takes a long time.	Cookware is too small, too heavy or the bottom is uneven.	Refer to "Hints and tips".

9.2 If you cannot find a solution...

If you cannot find a solution to the problem yourself, contact your dealer or an Authorised Service Centre. Give the data from the rating plate. Make sure, you operated the hob correctly. If not the servicing by a service

technician or dealer will not be free of charge, also during the warranty period. The information about guarantee period and Authorised Service Centres are in the service book.

10. TECHNICAL DATA

10.1 Rating plate

Model KIS8759
Typ 62 D5A 01 EA
Induction 7.35 kW
Ser.Nr.
ELECTROLUX

PNC 949 599 559 00
220 - 240 V, 50 Hz
Made in: Germany
7.35 kW



10.2 WiFi connection

WiFi frequency 2400 - 2483,5 MHz

EIRP max 20 dBm / 100 mW

10.3 Cooking zones specification

Cooking zone	Nominal power (maximum heat setting) [W]	Boost [W]	Boost maximum duration [min]	Cookware diameter [mm]
Left front	2300	3200	10	125 - 210
Left rear	2300	3200	10	125 - 210
Middle rear	2300	3200	10	125 - 210
Right front	2300	3200	10	125 - 210
Right rear	2300	3200	10	125 - 210

The power of the cooking zones can be different in some small range from the data in the table. It changes with the material and dimensions of the cookware.

For optimal heat transfer and cooking results use cookware with bottom diameter similar to

the size of the cooking zone (i.e. the maximum cookware diameter value in the table). Do not use cookware larger than the diameter of the cooking zone.

11. ENERGY EFFICIENCY

11.1 Energy saving

You can save energy during everyday cooking if you follow the hints below.

- When you heat up water, use only the amount you need.
- If it is possible, always put the lids on the cookware.

- Put the cookware directly in the centre of the cooking zone.

- Use the residual heat to keep the food warm or to melt it.

12. WARRANTY - AUSTRALIA AND NEW ZEALAND

FOR SALES IN AUSTRALIA AND NEW ZEALAND

APPLIANCE: ELECTROLUX BUILT-IN OVENS, COOKTOPS, FREESTANDING COOKER AND WARMING DRAWER

This document sets out the terms and conditions of the product warranties for Electrolux Appliances. It is an important document. Please keep it with your proof of purchase documents in a safe place for future reference should there be a manufacturing defect in your Appliance. This warranty is in addition to other rights you may have under the Australian Consumer Law.

1. In this warranty:

- 'ACL' or 'Australian Consumer Law' means Schedule 2 to the Competition and Consumer Act 2010;
- 'Appliance' means any Electrolux product purchased by you and accompanied by this document;
- 'ASC' means Electrolux's authorised serviced centres;
- 'Electrolux' is the brand controlled by Electrolux Home Products Pty Ltd of 163 O'Riordan Street, Mascot NSW 2020, ABN 51 004 762 341 in respect of Appliances purchased in Australia and Electrolux (NZ) Limited (collectively "Electrolux") of 3-5 Niall Burgess Road, Mount Wellington, in respect of Appliances purchased in New Zealand;
- 'Warranty Period' means the period specified in clause 3 of this warranty;
- 'you' means the purchaser of the Appliance not having purchased the Appliance for re-sale, and 'your' has a corresponding meaning.

- Application:** This warranty only applies to new Appliances, purchased and used in Australia or New Zealand and is in addition to (and does not exclude, restrict, or modify in any way) other rights and remedies under a law to which the

Appliances or services relate, including any nonexcludable statutory guarantees in Australia and New Zealand.

- Warranty Period:** Subject to these terms and conditions, this warranty continues for in Australia for a period of 36 months and in New Zealand for a period of 36 months, following the date of original purchase of the Appliance.
- Repair or replace warranty:** During the Warranty Period, Electrolux or its ASC will, at no extra charge if your Appliance is readily accessible for service, without special equipment and subject to these terms and conditions, repair or replace any parts which it considers to be defective. Electrolux may, in its absolute discretion, choose whether the remedy offered for a valid warranty claim is repair or replacement. Electrolux or its ASC may use refurbished parts to repair your Appliance. You agree that any replaced Appliances or parts become the property of Electrolux.
- Travel and transportation costs:** Subject to clause 7, Electrolux will bear the reasonable cost of transportation, travel and delivery of the Appliance to and from Electrolux or its ASC. Travel and transportation will be arranged by Electrolux as part of any valid warranty claim.
- Proof of purchase** is required before you can make a claim under this warranty.
- Exclusions:** You may not make a claim under this warranty unless the defect claimed is due to faulty or defective parts or workmanship. This warranty does not cover:
 - light globes, batteries, filters or similar perishable parts;
 - parts and Appliances not supplied by Electrolux;
 - cosmetic damage which does not affect the operation of the Appliance;
 - damage to the Appliance caused by:
 - negligence or accident;

- misuse or abuse, including failure to properly maintain or service;
- improper, negligent or faulty servicing or repair works done by anyone other than an Electrolux authorised repairer or ASC;
- normal wear and tear;
- power surges, electrical storm damage or incorrect power supply;
- incomplete or improper installation;
- incorrect, improper or inappropriate operation;
- insect or vermin infestation;
- failure to comply with any additional instructions supplied with the Appliance;

In addition, Electrolux is not liable under this warranty if:

- a. the Appliance has been, or Electrolux reasonably believes that the Appliance has been, used for purposes other than those for which the Appliance was intended, including where the Appliance has been used for any non-domestic purpose;
- b. the Appliance is modified without authority from Electrolux in writing;
- c. the Appliance's serial number or warranty seal has been removed or defaced

- 8. How to claim under this warranty:** To enquire about claiming under this warranty, please follow these steps:
- a. carefully check the operating instructions, user manual and the terms of this warranty;

- b. have the model and serial number of the Appliance available;
 - c. have the proof of purchase (e.g. an invoice) available;
 - d. telephone the numbers shown below.
- 9. Australia:** For Appliances and services provided by Electrolux in Australia: Electrolux goods come with guarantees that cannot be excluded under the Australian Consumer Law. You are entitled to a replacement or refund for a major failure and for compensation for any other reasonably foreseeable loss or damage. You are also entitled to have the Appliance repaired or replaced if the Appliance fails to be of acceptable quality and the failure does not amount to a major failure. 'Acceptable quality' and 'major failure' have the same meaning as referred to in the ACL.
- 10. New Zealand:** For Appliances and services provided by Electrolux in New Zealand, the Appliances come with a guarantee by Electrolux pursuant to the provisions of the Consumer Guarantees Act, the Sale of Goods Act and the Fair Trading Act. Where the Appliance was purchased in New Zealand for commercial purposes the Consumer Guarantee Act does not apply.
- 11. Confidentiality:** You accept that if you make a warranty claim, Electrolux and its agents including ASC may exchange information in relation to you to enable Electrolux to meet its obligations under this warranty.

Important Notice

Before calling for service, please ensure that the steps listed in clause 8 above have been followed.

AUSTRALIA

FOR SERVICE

or to find the address of your nearest authorised service centre in Australia
PLEASE CALL 13 13 49

For the cost of a local call

FOR SPARE PARTS

or to find the address of your nearest spare parts centre in Australia
PLEASE CALL 13 13 50

For the cost of a local call

NEW ZEALAND

FOR SERVICE

or to find the address of your nearest
authorised service centre in New Zealand
PLEASE CALL 0800 10 66 10

FOR SPARE PARTS

or to find the address of your nearest
state spare parts centre in New Zealand
PLEASE CALL 0800 10 66 20

ECook_Warr_Jul19

13. ENVIRONMENTAL CONCERNS

Recycle materials with the symbol . Put the packaging in relevant containers to recycle it. Help protect the environment and human health by recycling waste of electrical and electronic appliances. Do not dispose of

appliances marked with the symbol  with the household waste. Return the product to your local recycling facility or contact your municipal office.







