

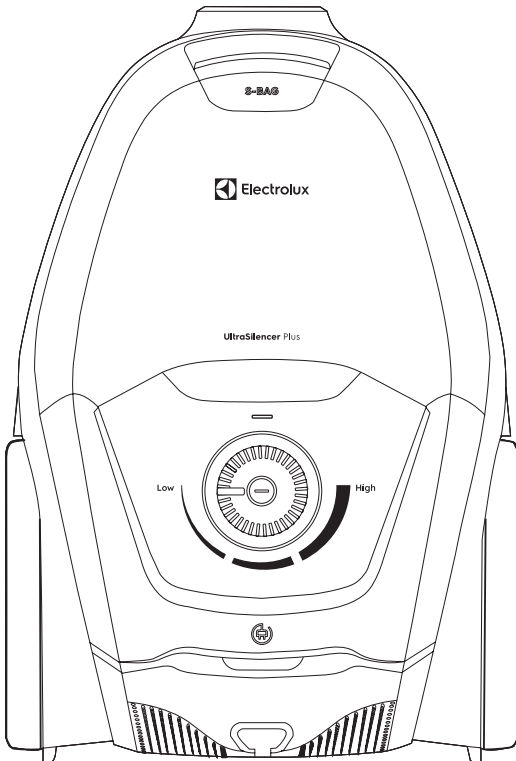

Electrolux

User Manual

UltraSilencer Plus Bagged Cleaner



SWEDISH THINKING, BETTER LIVING

With our Swedish heritage and care for homelife, we are passionate about creating effortless, sustainable homelife experiences that matter for you and our common future.

We want to make it more inspiring and effortless to eat healthily and sustainably and have set an ambitious goal for ourselves. Read more about our 2030 goals here:



VISIT OUR WEBSITE TO:



Get usage advice, brochures, trouble shooter, service information:
www.electrolux.com



Register your product for better service:
www.electrolux.com/productregistration



Buy accessories and consumables for your appliance:
www.electrolux.com/shop

CUSTOMER CARE AND SERVICE

When contacting Service, ensure that you have the following data available:

- Model number
- PNC number
- Serial number

The information can be found on the rating plate.

Subject to change without notice.

DESCRIPTION OF VACUUM CLEANER

1. Power cord
2. Exhaust filter lid
3. Exhaust filter
4. On-off button/rotary knob
5. Rewind button
6. Wheel
7. Motor filter holder
8. Dust compartment cover
9. S-bag
10. Motor filter
11. Hose
12. Handle
13. Caddy
14. 3in1 tool
15. Telescopic tube
16. AllFloor Auto nozzle
17. Parking slot
18. Upholstery nozzle
19. ParkettoPro nozzle

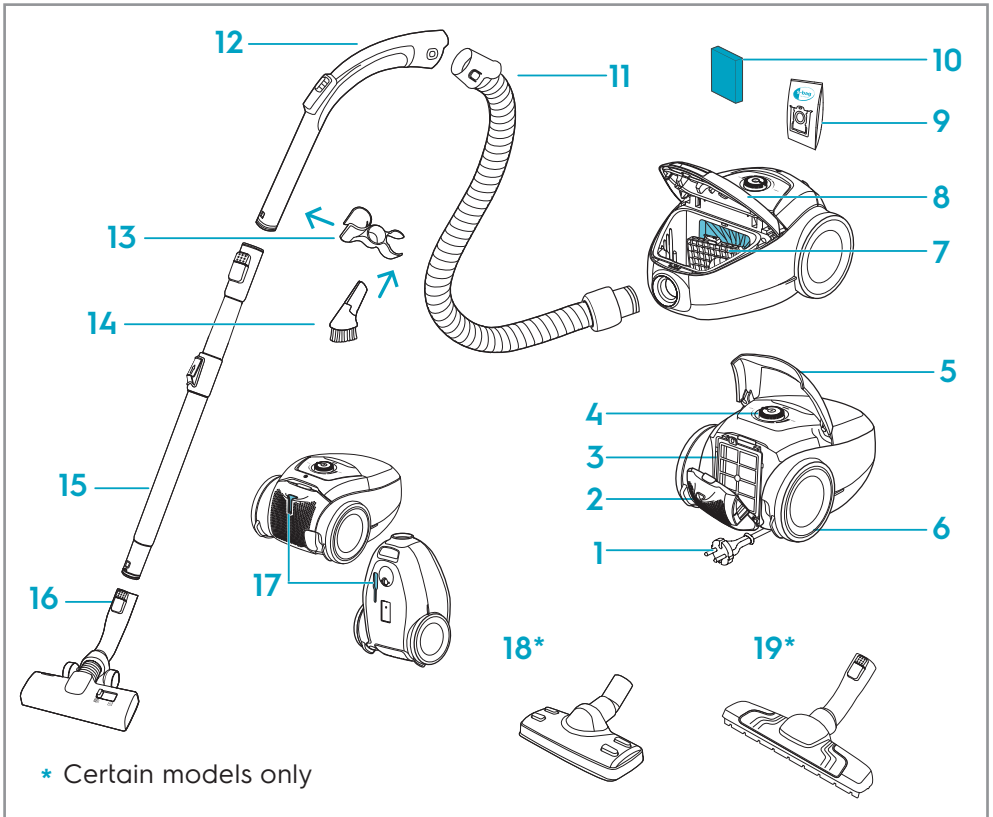

Power consumption in off mode: 0.3W

HOW TO INSTALL THE CLEANER

Open the dust compartment cover by pulling the S-BAG button. Check that the dust bag (s-bag) is in place.

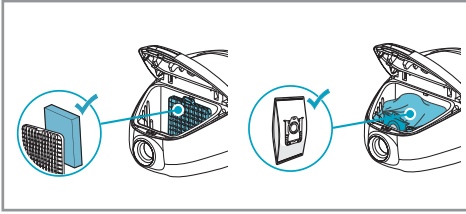

Insert the hose into the cleaner (to remove it, press the lock buttons and pull). Insert the hose into the hose handle until the lock button clicks (to release it, press the lock button and pull).

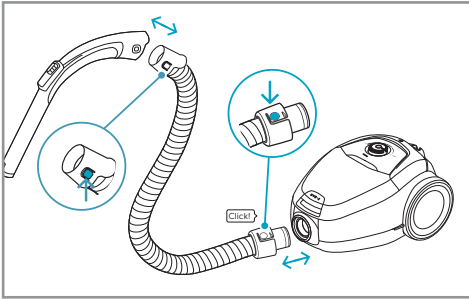

Attach the telescopic tube to the hose handle and the nozzle (to remove it, press the lock button and pull).

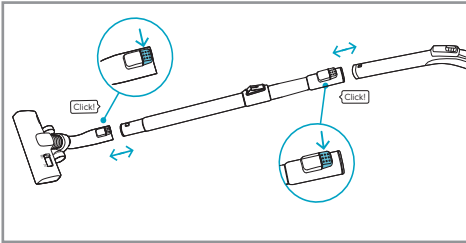

Adjust the telescopic tube by holding the lock with one hand and pulling the handle with the other hand.

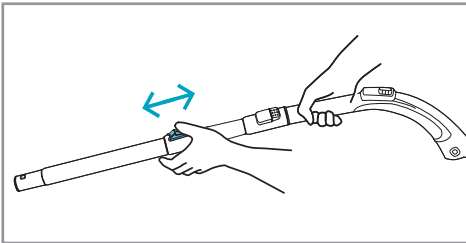

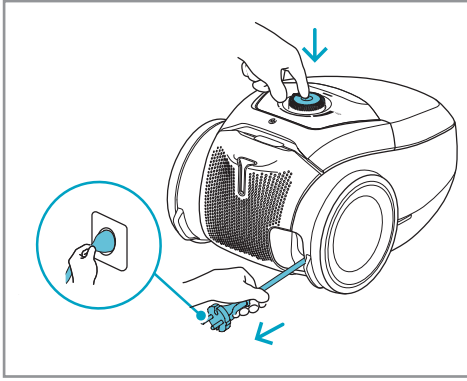

OPERATE THE CLEANER

Pull out the power cord and plug it into the mains. Press the ON/ OFF button to turn the cleaner on/ off.

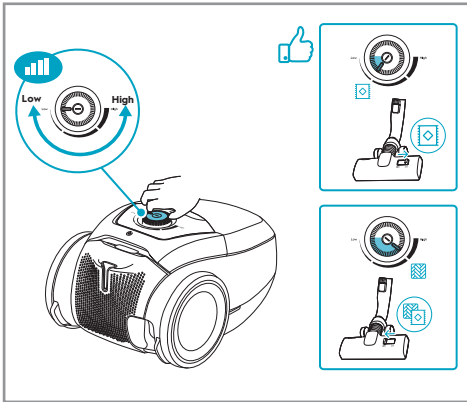

Turn the rotary knob on the cleaner to adjust suction power.

- i** For carpets, it is possible to use less power to get smooth operation and minimize motion resistance; for hard floors, more power can be used if necessary.

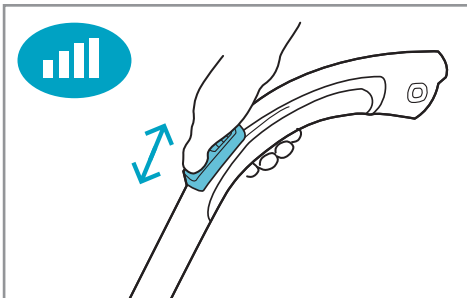

It also can use the air valve on the handle to regulate power.

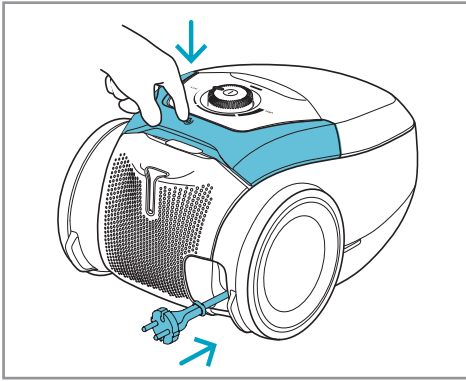

After cleaning, push the REWIND button to rewind the cable.

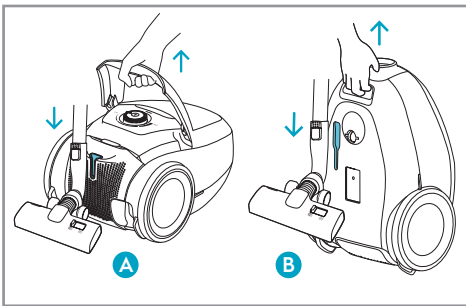

PARKING POSITIONS

Use parking position underneath (B) to carry and store the cleaner. At the back (A) when you pause (save your back)



REPLACING THE DUST BAG & MOTOR FILTER

Replace the s-bag when S-BAG indicator lights up in red (yellow light: soon time to replace bag). Open the dust compartment cover by pulling the S-BAG button.

- i** Always change the s-bag when S-BAG indicator is illuminated or has red light even if the s-bag is not full (it may be blocked) and after using carpet cleaning powder. Do not use paper dust bags! www.s-bag.com
- i** When you start the cleaner after s-bag replacement, it takes 10 seconds before the S-BAG indicator turns off or turns green.

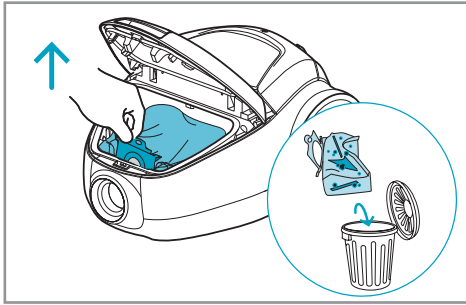

Pull the s-bag handle to close and remove the s-bag®.

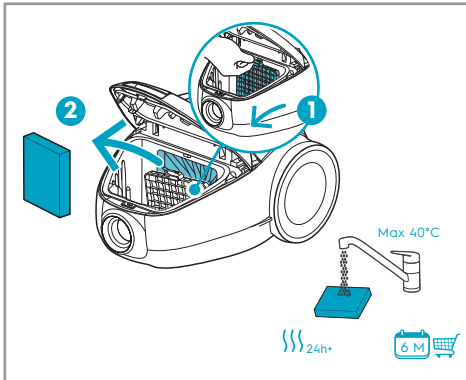

Clean the motor filter when dirty. Push the filter holder down and pull it out. Rinse the inside with lukewarm tap water and dry it completely (min. 24 h in room temperature).

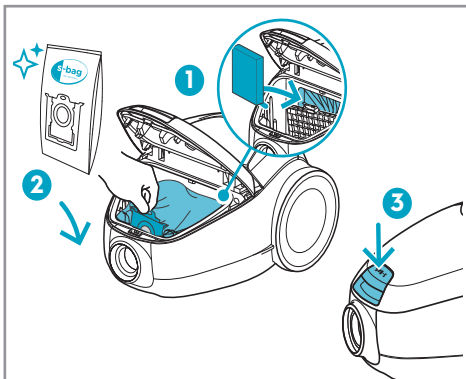

Put back the motor filter in place after cleaning. Insert a new s-bag® by pushing the cardboard straight down in its tracks. Close the lid. If the s-bag® is not properly placed or is missing, the lid will not close.

REPLACING THE EXHAUST FILTER

Lift the handle and press the **FILTER** button to open the filter lid. Replace/clean the exhaust filter at every fifth replacement of the dust bag (s-bag®). Use original filters: (EFS1W, EFH12W).

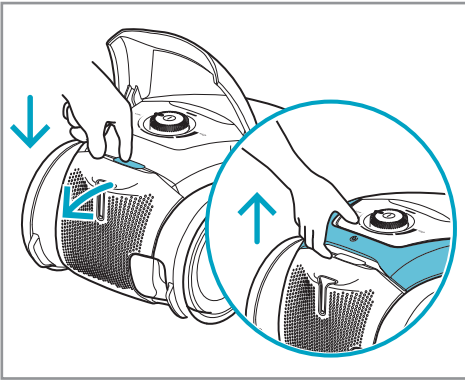

Lift out the filter. Rinse the inside (dirty side) in lukewarm tap water. Tap the filter frame to remove the water. Repeat the process four times. (washable filter only).

i Do not use cleaning agents. Avoid touching the filter surface. Let the filter dry completely (min. 24 h in room temperature) before putting back! Change the washable filter at least once a year or when it is very dirty or damage.

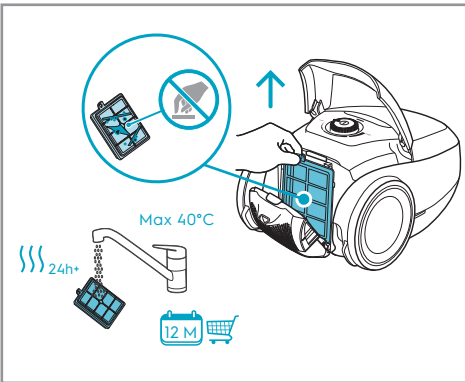

After inserting the filter, close the filter lid until it is clicked back into place.

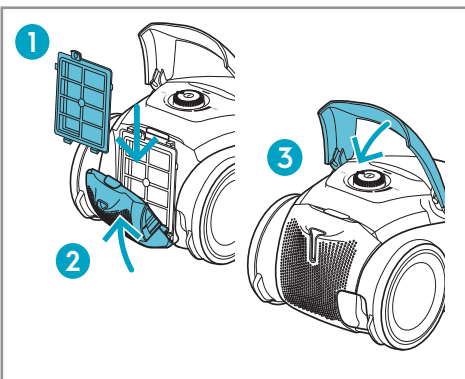

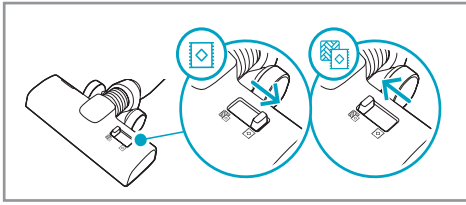

THE UNIVERSAL NOZZLE

For deep cleaning on carpet, change the nozzle setting with the slider to Carpet mode. Icon illustrates recommended floor type.

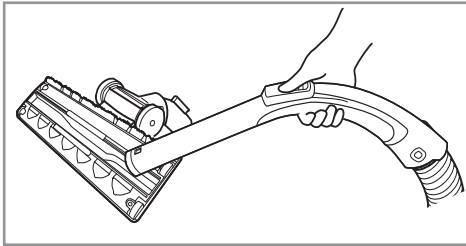









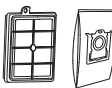

CLEANING OF THE NOZZLES

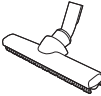

Disconnect the nozzle from the tube and clean with the hose handle.

ACCESSORIES AND SPARE PARTS

www.shop.electrolux.com

 <p>SRK206S 900 923 845 Starter Kit</p>	 <p>EFS1W 900 167 768 S-filter® Allergy Plus™ Filter(Washable)</p>	 <p>EFH12W 900 195 119 S-filter® Hygiene Filter(Washable)</p>	 <p>E201S 900 168 458 S-bag® Classic Long Performance</p>	 <p>E201S 900 168 461 S-bag® Ultra Long Performance</p>
 <p>E203S 900 168 459 S-bag® Anti-Odour</p>	 <p>E206S 900 168 460 S-bag® Hygiene Anti-Allergy</p>	 <p>KIT09C 900 923 349 Home & Car Kit</p>	 <p>ZE161 900 923 558 Extra Wide Nozzle</p>	 <p>ZE165 900 168 381 Speedy Clean Nozzle</p>

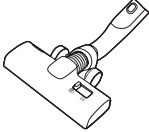
TIPS ON HOW TO GET THE BEST RESULTS

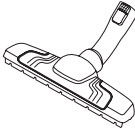
NOZZLE/ ACCESSORY	USE FOR:
	<p>Universal nozzle:</p> <ul style="list-style-type: none"> - For all floor types, secures excellent dust pick up both on carpets and hard floors. - Recommended to use Allfloor mode, which enables going from hard floor to carpet without adjusting the setting. - For deep cleaning on carpet, change the nozzle setting with the slider to Carpet mode.
	<p>3 tools in 1:</p> <ol style="list-style-type: none"> 1. Dusting tool for hard surfaces (bookshelves, skirting boards etc). 2. Upholstery tool for textiles (curtains, upholstery etc). 3. Crevice tool for narrow spaces (behind radiators etc).
	<p>Upholstery nozzle:</p> <ul style="list-style-type: none"> - Use the upholstery nozzle for sofas, curtains, lightweight fabrics etc (for removal of hair, pet hair, fibres etc.) Reduce suction power if necessary.
	<p>Hard floor nozzle:</p> <ul style="list-style-type: none"> - For gentle cleaning of hard floor (parquet, wooden floor, tiles etc). - Best dust pick up on hard floor with crevice.

TROUBLESHOOTING

PROBLEM	SOLUTION
The vacuum cleaner does not start	<ul style="list-style-type: none"> · Check that the cable is connected to the mains. · Check that the plug and cable are not damaged. · Check for a blown fuse. · Check if the battery indicator lamp in the remote control handle responds (certain models only).
The s-bag® indicator light is illuminated	<ul style="list-style-type: none"> · Check if the s-bag® is full or blocked. · If you have already changed the s-bag®, change the motor filter.
The cleaner stops	<p>The cleaner might be overheated: disconnect it from the mains; check if the nozzle, tube, hose or filters are blocked. Let the cleaner cool down for 30 minutes before plugging it in again.</p> <p>If the cleaner still does not work, contact an authorized service centre.</p>
Reduction of suction capacity versus normal	<ul style="list-style-type: none"> · Check if the s-bag is full or blocked. · Check if the motor filter is clogged and needs changing. · Check if nozzle is blocked and needs to be cleared. · Check if hose is blocked by squeezing it gently. However, be careful in case the obstruction has been caused by glass or needles caught inside the hose. <p>Note: The warranty does not cover any damage to the hose caused by cleaning it</p>
Water has been sucked into the vacuum cleaner	It will be necessary to replace the motor at an authorized service centre. Damage to the motor caused by the penetration of water is not covered by the warranty.
For any further problems, contact an authorized service centre.	

Environment Concerns

Recycle materials with the symbol . Put the packaging in relevant containers to recycle it. Help protect the environment and human health by recycling waste of electrical and electronic appliances.

Do not dispose appliances marked with the symbol  with the household waste. Return the product to your local recycling facility or contact your municipal office.

For Switzerland:

Where should you take your old equipment? Any where that sells new equipment or hand it in to official SENS collection points or official SENS recycling firms. The list of official SENS collection points can be found at www.erecycling.chseconds